























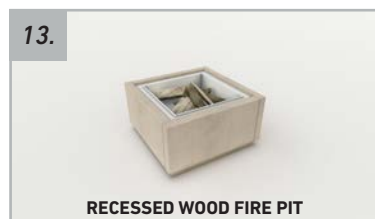

# ARTFORMS™

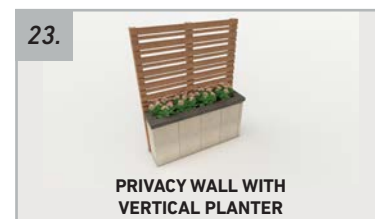
MODULAR PANEL SYSTEM

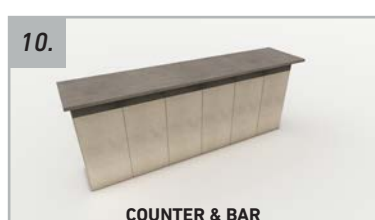
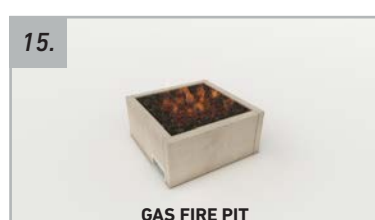

IDEA BOOK

# TABLE OF CONTENTS

<p>1.</p>  <p>BENCH &amp; PLANTER</p>	<p>6.</p>  <p>LONG BBQ</p>	<p>11.</p>  <p>LARGE COUNTER</p>	<p>16.</p>  <p>RECESSED RECTANGULAR GAS FIRE PIT</p>	<p>21.</p>  <p>PRIVACY WALL WITH BENCH</p>
<p>2.</p>  <p>CORNER BENCH &amp; PLANTER</p>	<p>7.</p>  <p>L-SHAPE BBQ</p>	<p>12.</p>  <p>LUXURY COUNTER &amp; BAR</p>	<p>17.</p>  <p>RECTANGULAR GAS FIRE PIT</p>	<p>22.</p>  <p>PRIVACY WALL WITH PLANTER</p>
<p>3.</p>  <p>BENCH &amp; VERTICAL PLANTER</p>	<p>8.</p>  <p>CORNER BBQ &amp; PIZZA GRILL</p>	<p>13.</p>  <p>RECESSED WOOD FIRE PIT</p>	<p>18.</p>  <p>SQUARE PLANTER</p>	<p>23.</p>  <p>PRIVACY WALL WITH VERTICAL PLANTER</p>
<p>4.</p>  <p>SMALL BBQ</p>	<p>9.</p>  <p>BBQ WITH LUXURY COUNTER &amp; BAR</p>	<p>14.</p>  <p>RECESSED GAS FIRE PIT</p>	<p>19.</p>  <p>RECTANGULAR PLANTER</p>	<p>24.</p>  <p>RAISED GARDEN</p>
<p>5.</p>  <p>MEDIUM BBQ</p>	<p>10.</p>  <p>COUNTER &amp; BAR</p>	<p>15.</p>  <p>GAS FIRE PIT</p>	<p>20.</p>  <p>VERTICAL PLANTER</p>	<p>25.</p>  <p>CORNER MULTILEVEL RAISED GARDEN</p>

# TABLE OF CONTENTS

26.



MULTILEVEL RAISED GARDEN

28.



L-SHAPE BENCH WITH  
VERTICAL PLANTER

30.



HIGH TOP GAS FIREPIT

27.



FIREPLACE WITH BENCH  
& WOOD PERGOLA

29.



BBQ WITH BENCH &  
VERTICAL PLANTER

31.



CORNER BENCH & FIRE PIT

# 1. BENCH & PLANTER



INTERIOR VIEW

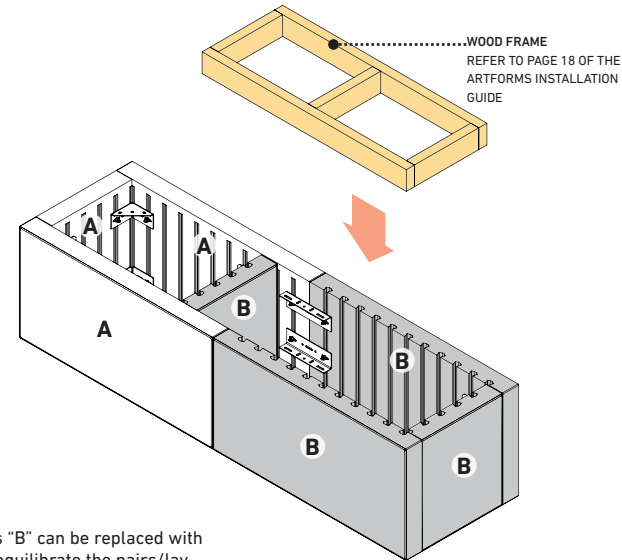

**NOTE:** Panels "B" can be replaced with panels "A" to equilibrate the pairs/layers. Panels "A" can't be replaced by the panels "B".

## REQUIRED PANELS

	18 x 36 PANEL	<b>3x</b>
	18 x 36 PANEL	<b>3x</b>
	6 x 36 PANEL	<b>0x</b>
	6 x 36 PANEL	<b>0x</b>

**IMPORTANT:** 18 x 36 panels are sold in pair/layer or in full pallet only. 6 x 36 panels are sold per unit or in layer or in full pallet.

FRONT VIEW

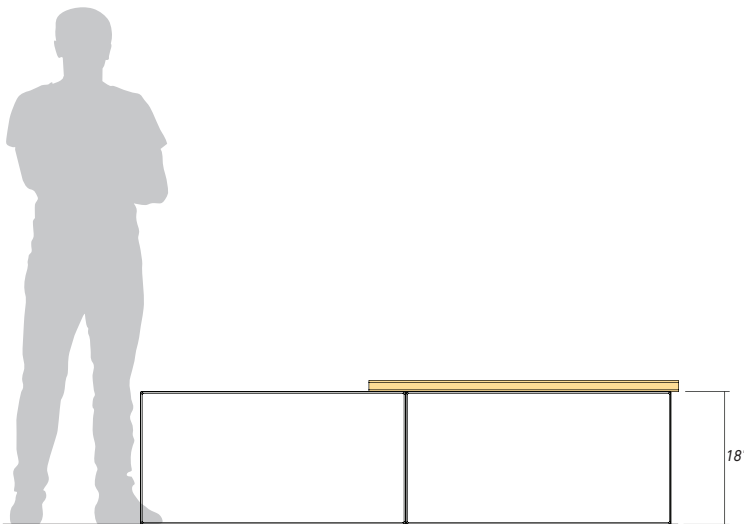

TOP VIEW

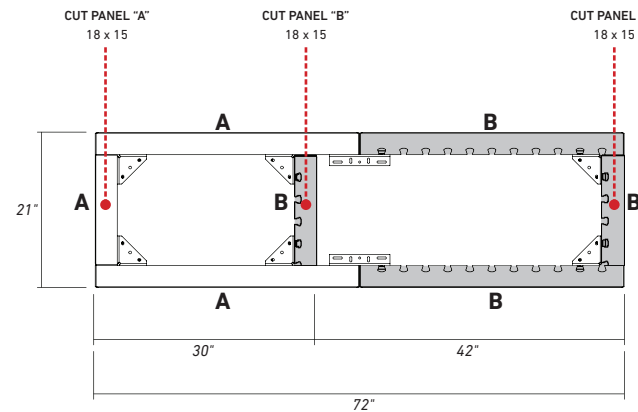

## REQUIRED HARDWARE

	ANCHOR SLIDE AND NUT	<b>32x</b>
	JOINING PLATE	<b>4x</b>
	OUTER CORNER	<b>12x</b>
	INNER CORNER	<b>0x</b>
	STRETCHER	<b>0x</b>

**IMPORTANT:** Refer to page 23 of the ARTFORMS INSTALLATION GUIDE about the installation of geotextile in planter box. Contact experts/engineers to validate the base preparation, the drainage, the plants & roots growth/management.

# 2. CORNER BENCH & PLANTER



INTERIOR VIEW

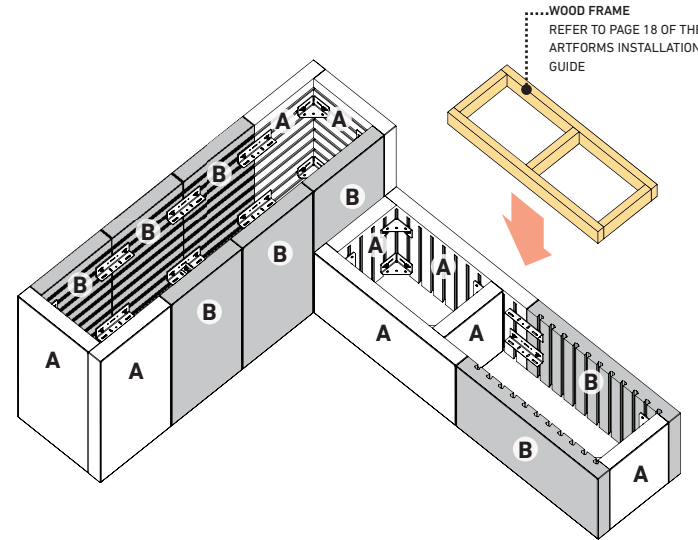

**NOTE:** Panels "B" can be replaced with panels "A" to equilibrate the pairs/layers. Panels "A" can't be replaced by the panels "B".

## REQUIRED PANELS

CLOSED END		18 x 36 PANEL	<b>8x</b>
		18 x 36 PANEL	<b>8x</b>
CLOSED END		6 x 36 PANEL	<b>0x</b>
		6 x 36 PANEL	<b>0x</b>

**IMPORTANT:** 18 x 36 panels are sold in pair/layer or in full pallet only. 6 x 36 panels are sold per unit or in layer or in full pallet.

FRONT VIEW

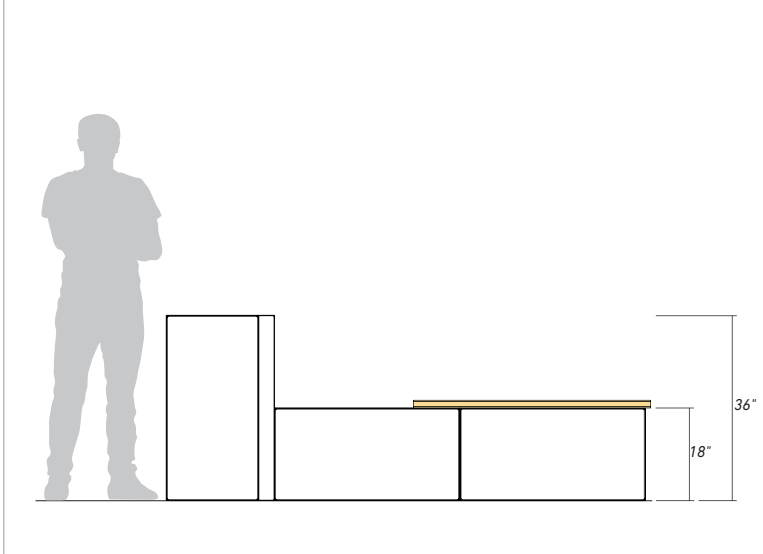

TOP VIEW

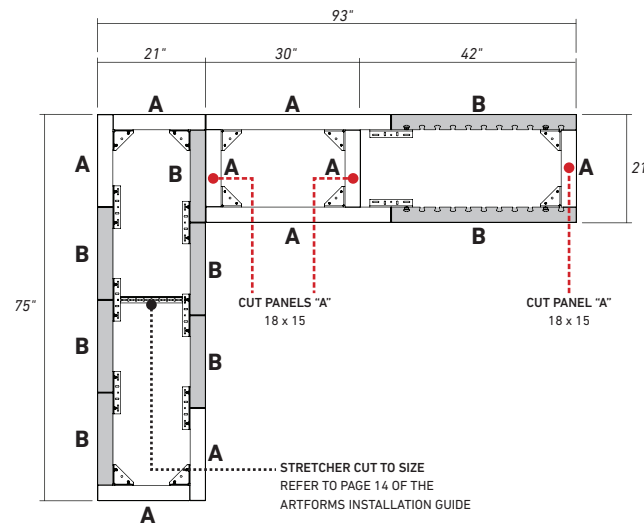

## REQUIRED HARDWARE

	ANCHOR SLIDE AND NUT	<b>74x</b>
	JOINING PLATE	<b>16x</b>
	OUTER CORNER	<b>20x</b>
	INNER CORNER	<b>0x</b>
	STRETCHER	<b>1x</b>

**IMPORTANT:** Refer to page 23 of the ARTFORMS INSTALLATION GUIDE about the installation of geotextile in planter box. Contact experts/engineers to validate the base preparation, the drainage, the plants & roots growth/management.

# 3. BENCH & VERTICAL PLANTER



## INTERIOR VIEW

WOOD FRAME  
REFER TO PAGE 18 OF THE  
ARTFORMS INSTALLATION  
GUIDE

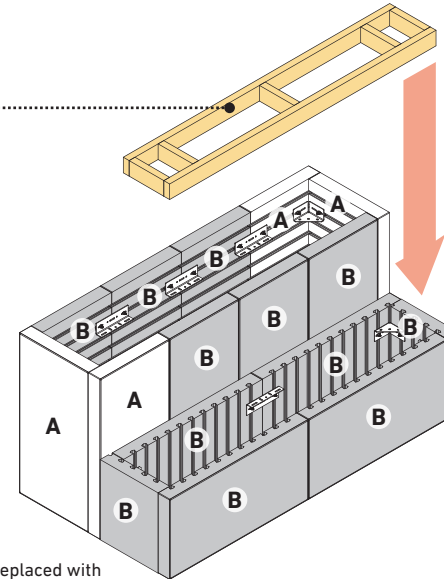

**NOTE:** Panels "B" can be replaced with panels "A" to equilibrate the pairs/layers. Panels "A" can't be replaced by the panels "B".

## REQUIRED PANELS

CLOSED END 18 x 36 PANEL	<b>4x</b>
18 x 36 PANEL	<b>11x</b>
CLOSED END 6 x 36 PANEL	<b>0x</b>
6 x 36 PANEL	<b>0x</b>

**IMPORTANT:** 18 x 36 panels are sold in pair/layer or in full pallet only. 6 x 36 panels are sold per unit or in layer or in full pallet.

## FRONT VIEW

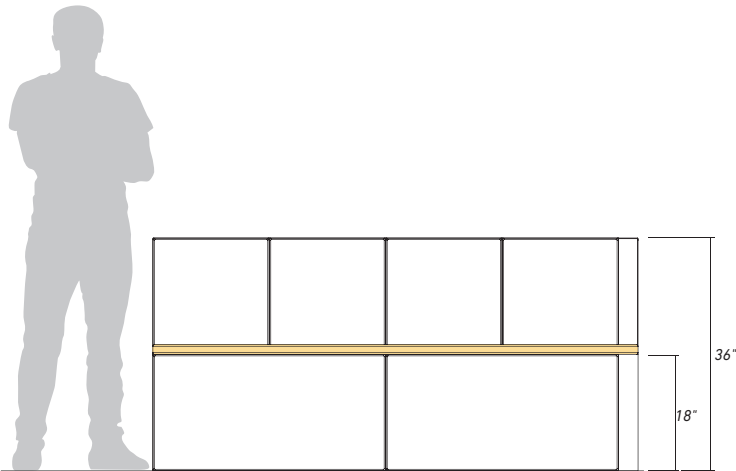

## TOP VIEW

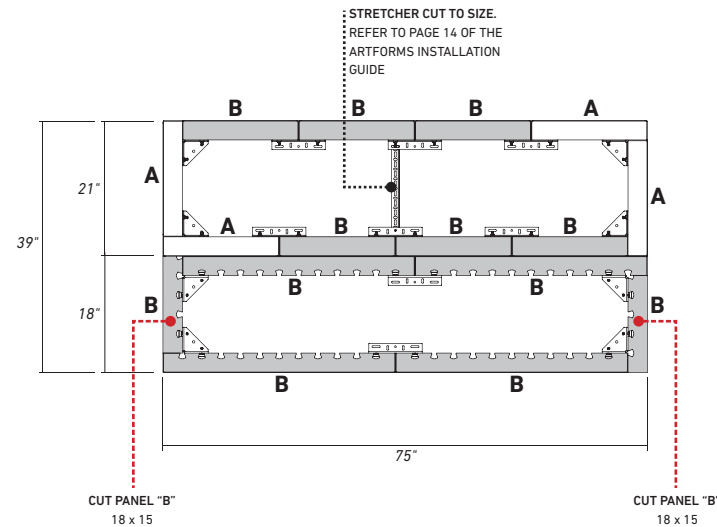

## REQUIRED HARDWARE

ANCHOR SLIDE AND NUT	<b>66x</b>
JOINING PLATE	<b>16x</b>
OUTER CORNER	<b>16x</b>
INNER CORNER	<b>0x</b>
STRETCHER	<b>1x</b>

**IMPORTANT:** Refer to page 23 of the ARTFORMS INSTALLATION GUIDE about the installation of geotextile in planter box. Contact experts/engineers to validate the base preparation, the drainage, the plants & roots growth/management.

# 4. SMALL BBQ



## INTERIOR VIEW

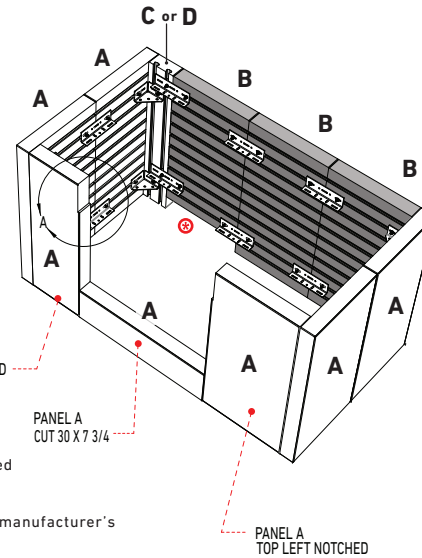
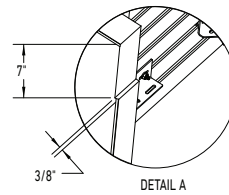

**NOTE:** In DETAIL A, 7" height is related to a countertop thickness of 1".

⊗ Cut panel(s) according to the BBQ manufacturer's specifications for ventilation.

**NOTE:** Panels "B" can be replaced with panels "A" to equilibrate the pairs/layers. Panels "A" can't be replaced by the panels "B".

## REQUIRED PANELS

	<b>7x</b>
	<b>3x</b>
	<b>0x</b>
	<b>1x</b>

**IMPORTANT:** 18 x 36 panels are sold in pair/layer or in full pallet only. 6 x 36 panels are sold per unit or in layer or in full pallet.

## FRONT VIEW

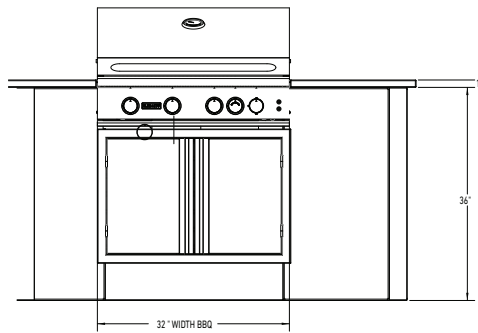

## TOP VIEW

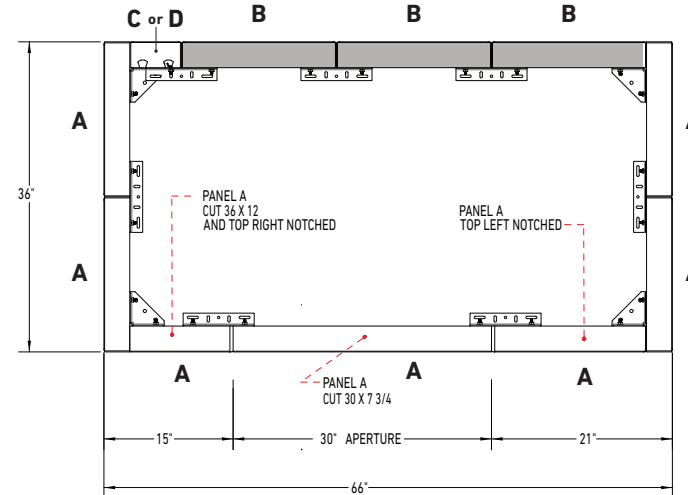

## REQUIRED HARDWARE

	<b>40x</b>
	<b>12x</b>
	<b>8x</b>
	<b>0x</b>
	<b>0x</b>

**IMPORTANT:** It is recommended to follow the BBQ manufacturer's specifications for ventilation and clearances. Belgard is not responsible for the conformity of connections, clearances and ventilation. BBQ, countertop and accessories are not included.

**TOTAL WEIGHT (PANELS & HARDWARE) 1363 Lbs**

# 5. MEDIUM BBQ



## INTERIOR VIEW

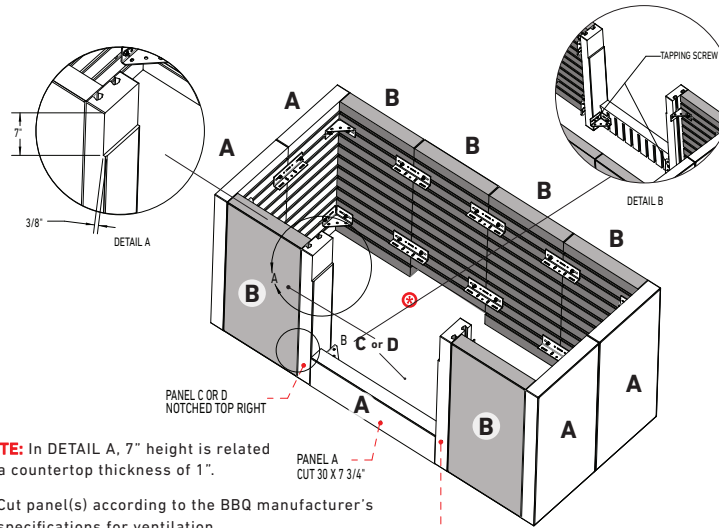

**NOTE:** In DETAIL A, 7" height is related to a countertop thickness of 1".

⊕ Cut panel(s) according to the BBQ manufacturer's specifications for ventilation.

**NOTE:** Panels "B" can be replaced with panels "A" to equilibrate the pairs/layers. Panels "A" can't be replaced by the panels "B".

## REQUIRED PANELS

	5x
	6x
	0x
	2x

**IMPORTANT:** 18 x 36 panels are sold in pair/layer or in full pallet only. 6 x 36 panels are sold per unit or in layer or in full pallet.

## FRONT VIEW

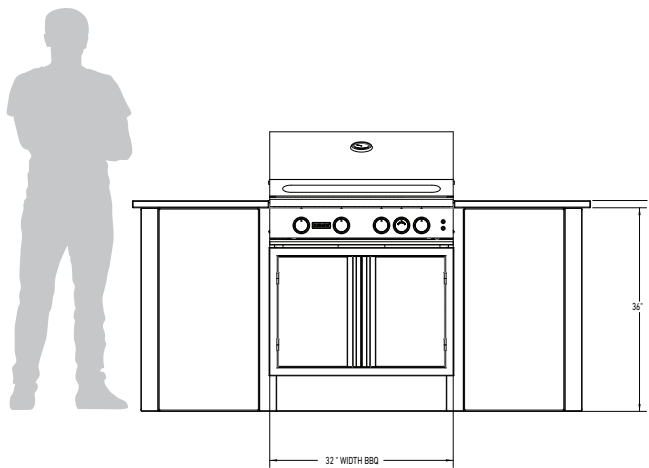

## TOP VIEW

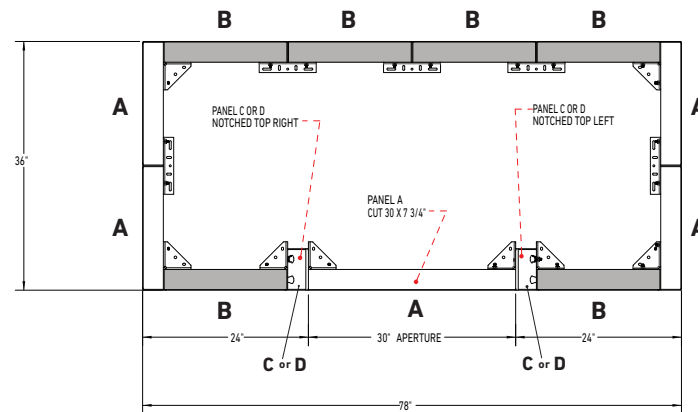

## REQUIRED HARDWARE

	ANCHOR SLIDE AND NUT	48x
	JOINING PLATE	10x
	OUTER CORNER	14x
	INNER CORNER	0x
	STRETCHER	0x

**IMPORTANT:** It is recommended to follow the BBQ manufacturer's specifications for ventilation and clearances. Belgard is not responsible for the conformity of connections, clearances and ventilation. BBQ, countertop and accessories are not included.



# 6. LONG BBQ



## INTERIOR VIEW

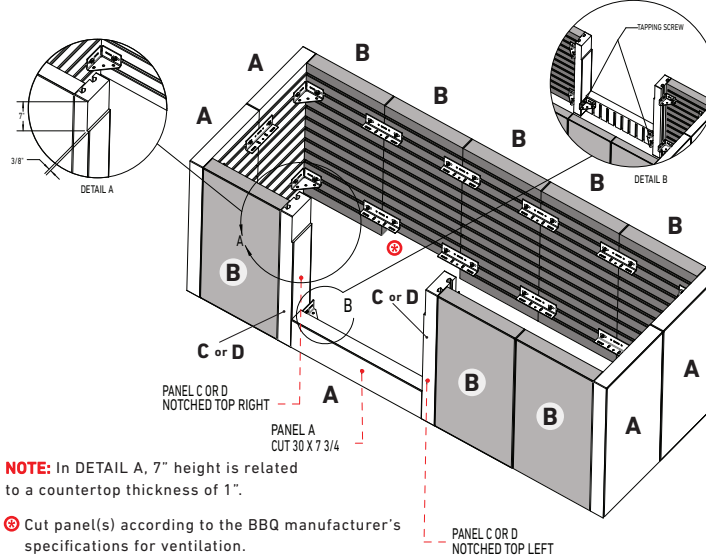

**NOTE:** In DETAIL A, 7" height is related to a countertop thickness of 1".

⊕ Cut panel(s) according to the BBQ manufacturer's specifications for ventilation.

**NOTE:** Panels "B" can be replaced with panels "A" to equilibrate the pairs/layers. Panels "A" can't be replaced by the panels "B".

## REQUIRED PANELS

	5x
	8x
	2x
	0x

**IMPORTANT:** 18 x 36 panels are sold in pair/layer or in full pallet only. 6 x 36 panels are sold per unit or in layer or in full pallet.

## FRONT VIEW

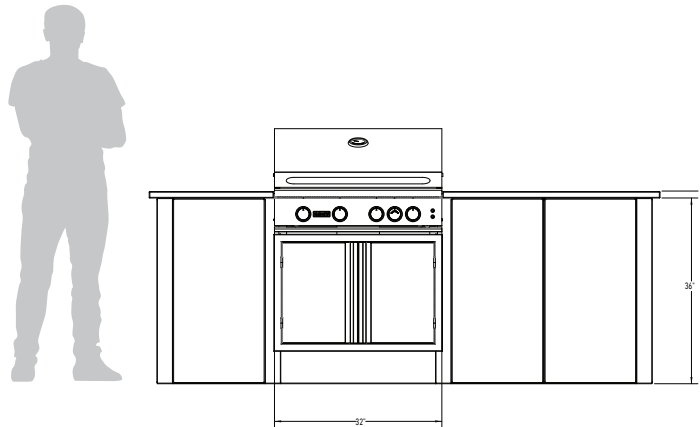

## TOP VIEW

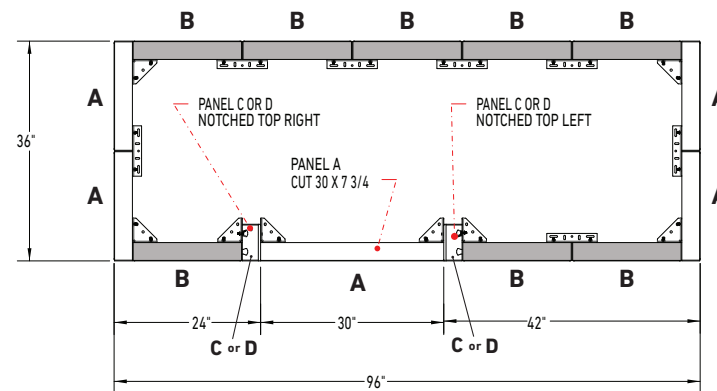

## REQUIRED HARDWARE

	ANCHOR SLIDE AND NUT	56x
	JOINING PLATE	14x
	OUTER CORNER	14x
	INNER CORNER	0x
	STRETCHER	0x

**IMPORTANT:** It is recommended to follow the BBQ manufacturer's specifications for ventilation and clearances. Belgard is not responsible for the conformity of connections, clearances and ventilation. BBQ, countertop and accessories are not included.

# 7. L-SHAPE BBQ



INTERIOR VIEW

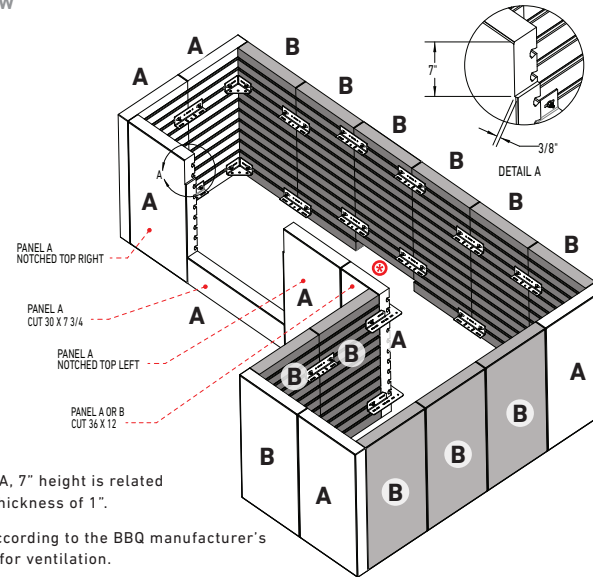

**NOTE:** In DETAIL A, 7" height is related to a countertop thickness of 1".

⊕ Cut panel(s) according to the BBQ manufacturer's specifications for ventilation.

**NOTE:** Panels "B" can be replaced with panels "A" to equilibrate the pairs/layers. Panels "A" can't be replaced by the panels "B".

## REQUIRED PANELS

CLOSED END 18 x 36 PANEL	<b>9x</b>
18 x 36 PANEL	<b>11x</b>
CLOSED END 6 x 36 PANEL	<b>0x</b>
6 x 36 PANEL	<b>0x</b>

**IMPORTANT:** 18 x 36 panels are sold in pair/layer or in full pallet only. 6 x 36 panels are sold per unit or in layer or in full pallet.

FRONT VIEW

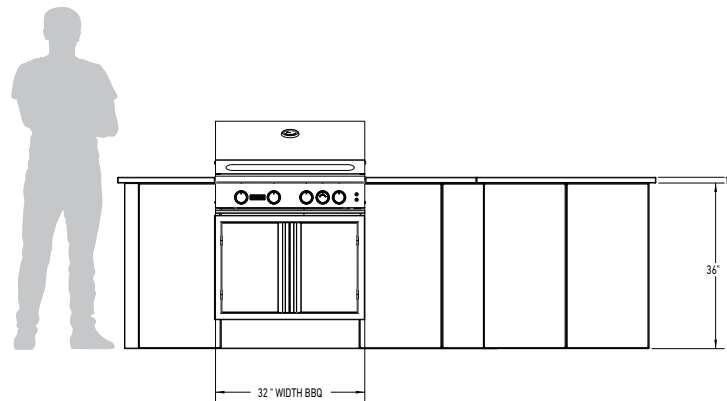

TOP VIEW

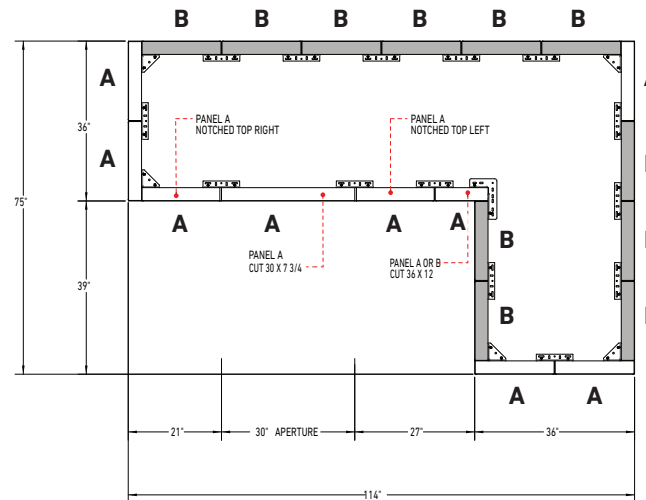

## REQUIRED HARDWARE

ANCHOR SLIDE AND NUT	<b>76x</b>
JOINING PLATE	<b>26x</b>
OUTER CORNER	<b>10x</b>
INNER CORNER	<b>2x</b>
STRETCHER	<b>1x</b>

**IMPORTANT:** It is recommended to follow the BBQ manufacturer's specifications for ventilation and clearances. Belgard is not responsible for the conformity of connections, clearances and ventilation. BBQ, countertop and accessories are not included.

# 8. CORNER BBQ & PIZZA GRILL



INTERIOR VIEW

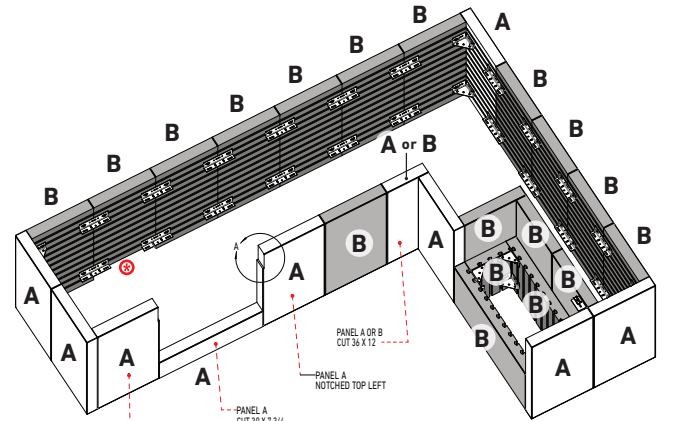

⊕ Cut panel(s) according to the BBQ manufacturer's specifications for ventilation.

**NOTE:** Panels "B" can be replaced with panels "A" to equilibrate the pairs/layers. Panels "A" can't be replaced by the panels "B".

**NOTE:** In DETAIL A, 7" height is related to a countertop thickness of 1".

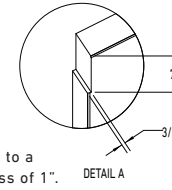

## REQUIRED PANELS

- 10x
- 18x
- 0x
- 0x

**IMPORTANT:** 18 x 36 panels are sold in pair/layer or in full pallet only. 6 x 36 panels are sold per unit or in layer or in full pallet.

FRONT VIEW

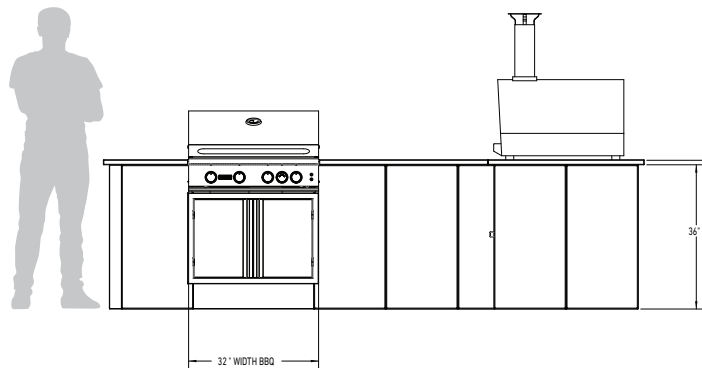

TOP VIEW

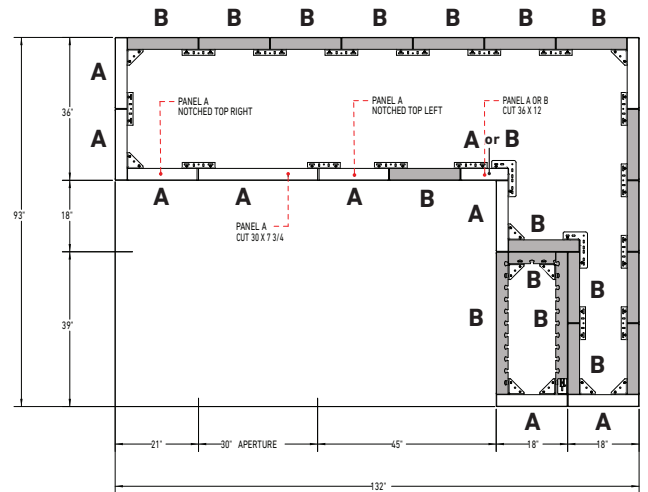

## REQUIRED HARDWARE

- 110x
- 30x
- 21x
- 4x
- 1x

**IMPORTANT:** It is recommended to follow the BBQ manufacturer's specifications for ventilation and clearances. Belgard is not responsible for the conformity of connections, clearances and ventilation. BBQ, countertop and accessories are not included.

# 8. CORNER BBQ & PIZZA GRILL

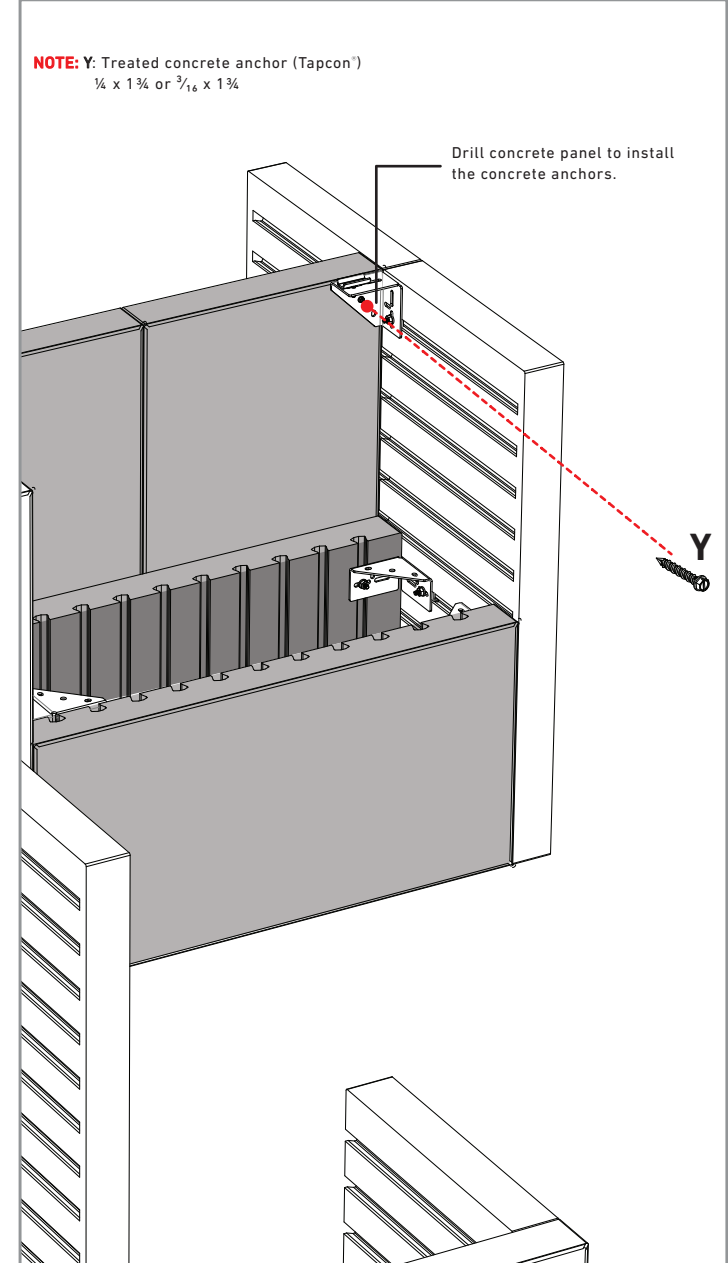
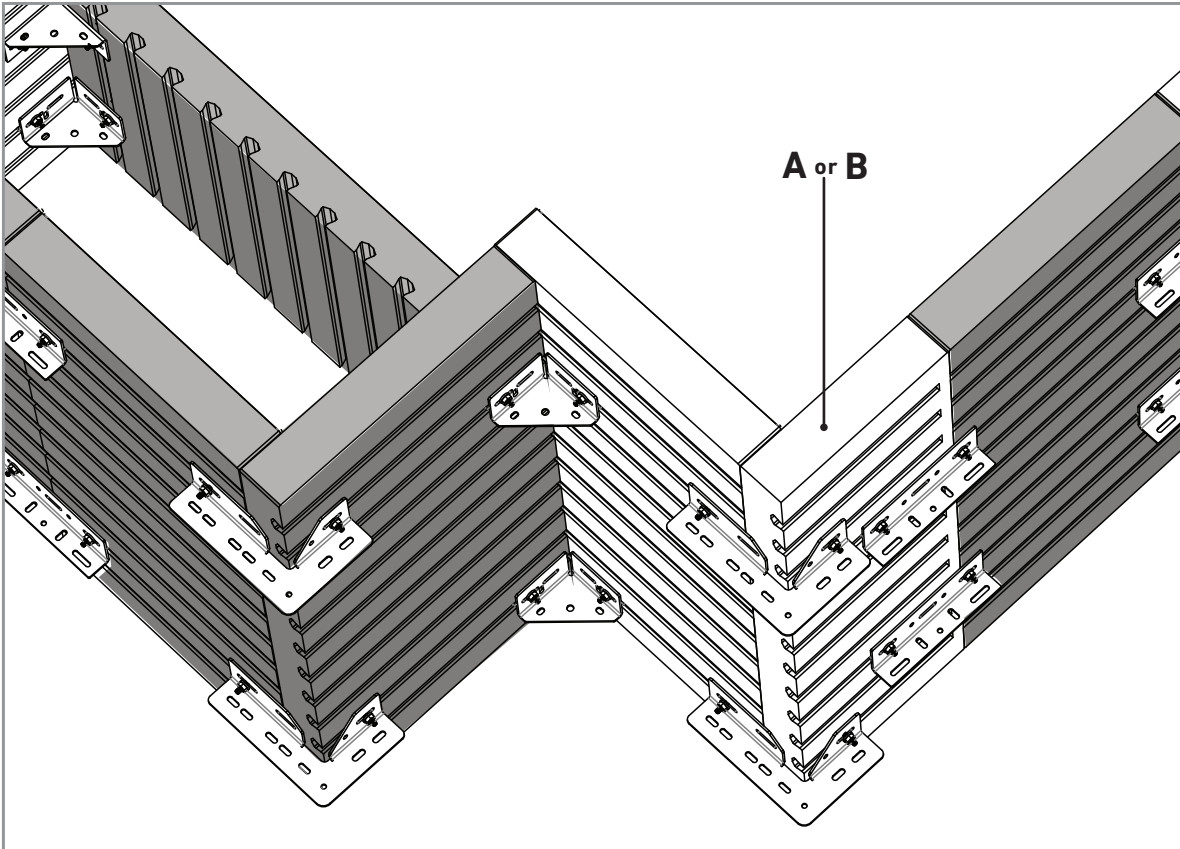
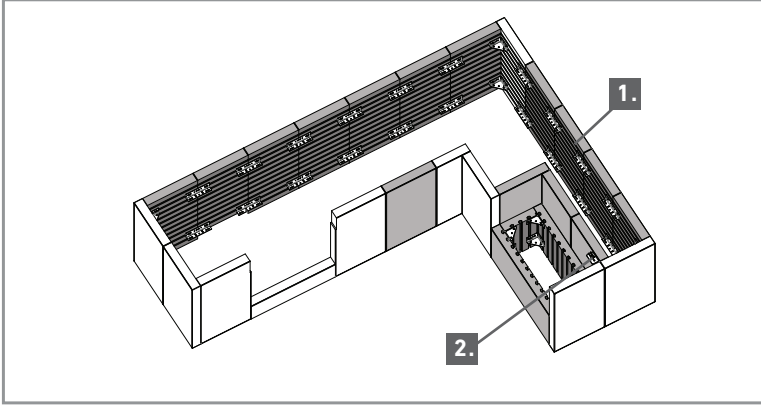

**IMPORTANT:** It is recommended to follow the BBQ manufacturer's specifications for ventilation and clearances. Belgard is not responsible for the conformity of connections, clearances and ventilation. BBQ, countertop and accessories are not included.

# BBQ WITH LUXURY COUNTER & BAR



FRONT VIEW

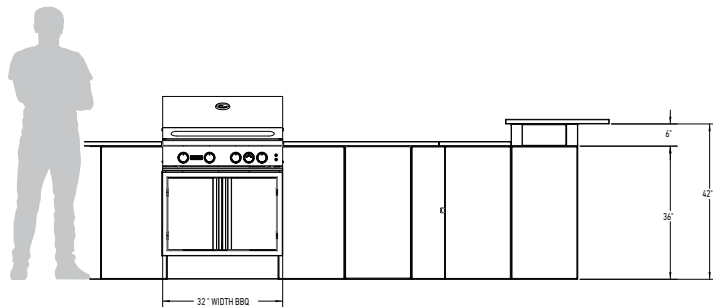

TOP VIEW

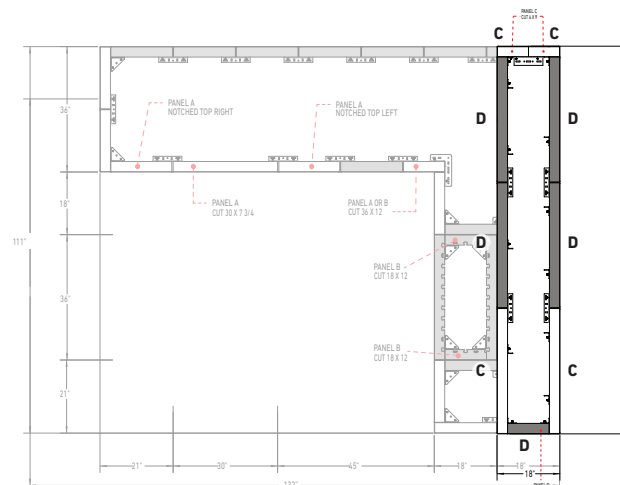
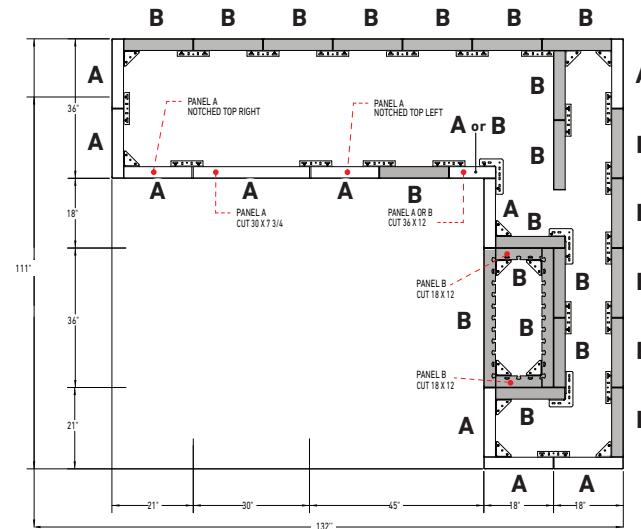

## REQUIRED PANELS

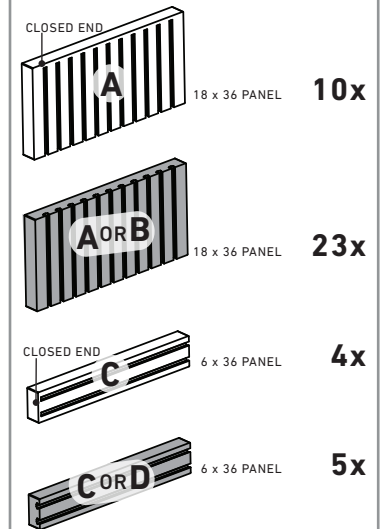

**IMPORTANT:** 18 x 36 panels are sold in pair/layer or in full pallet only. 6 x 36 panels are sold per unit or in layer or in full pallet.

## REQUIRED HARDWARE

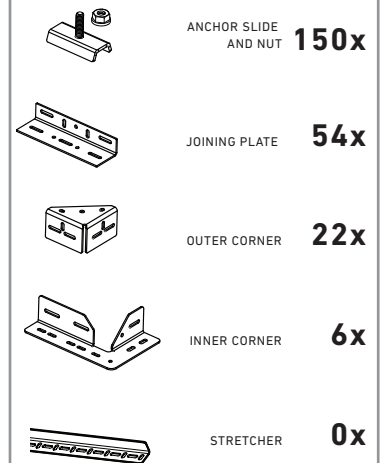

**IMPORTANT:** It is recommended to follow the BBQ manufacturer's specifications for ventilation and clearances. Belgard is not responsible for the conformity of connections, clearances and ventilation. BBQ, countertop and accessories are not included.

# BBQ WITH LUXURY COUNTER & BAR

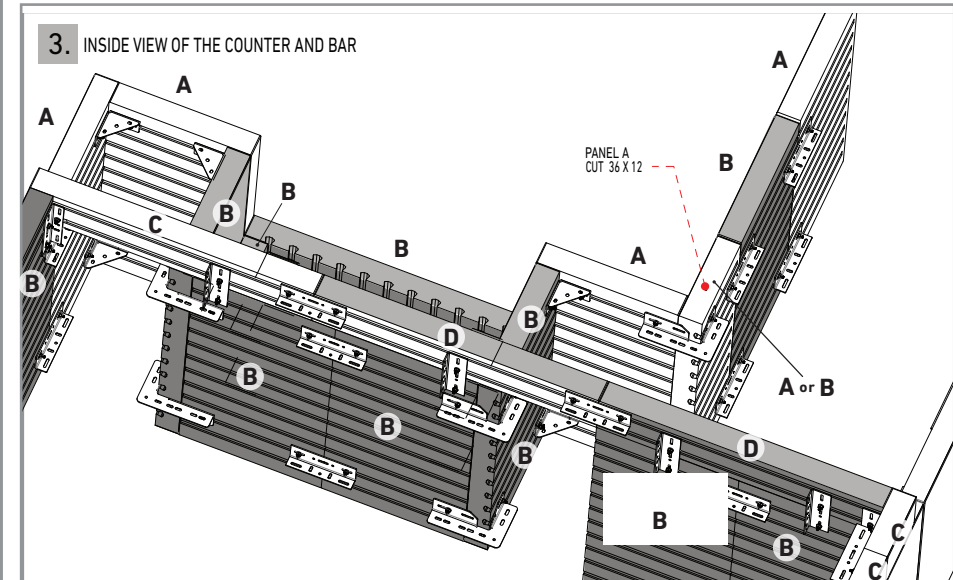
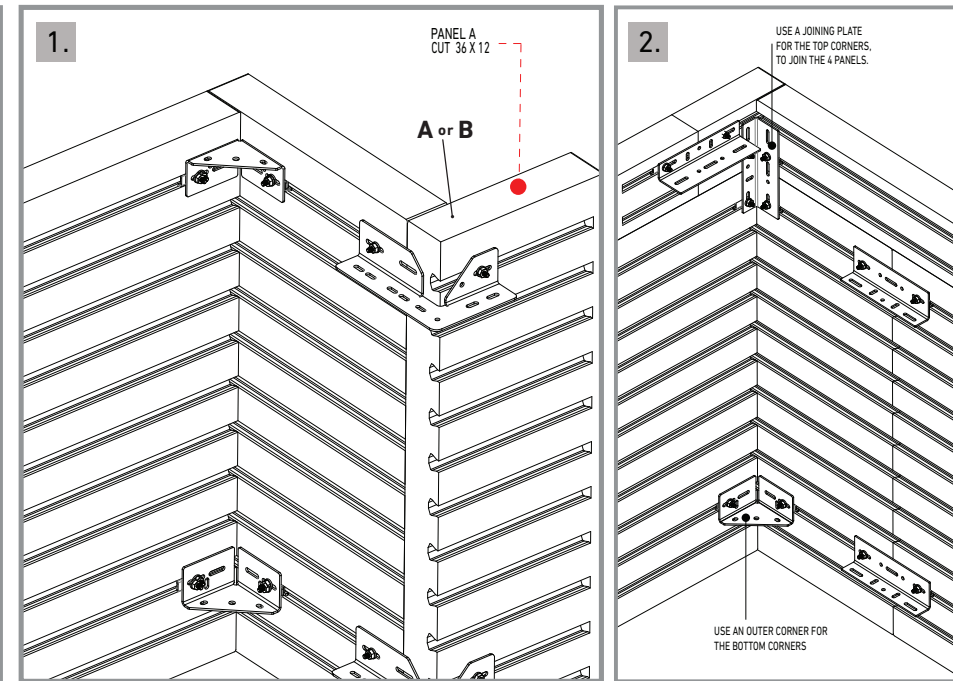
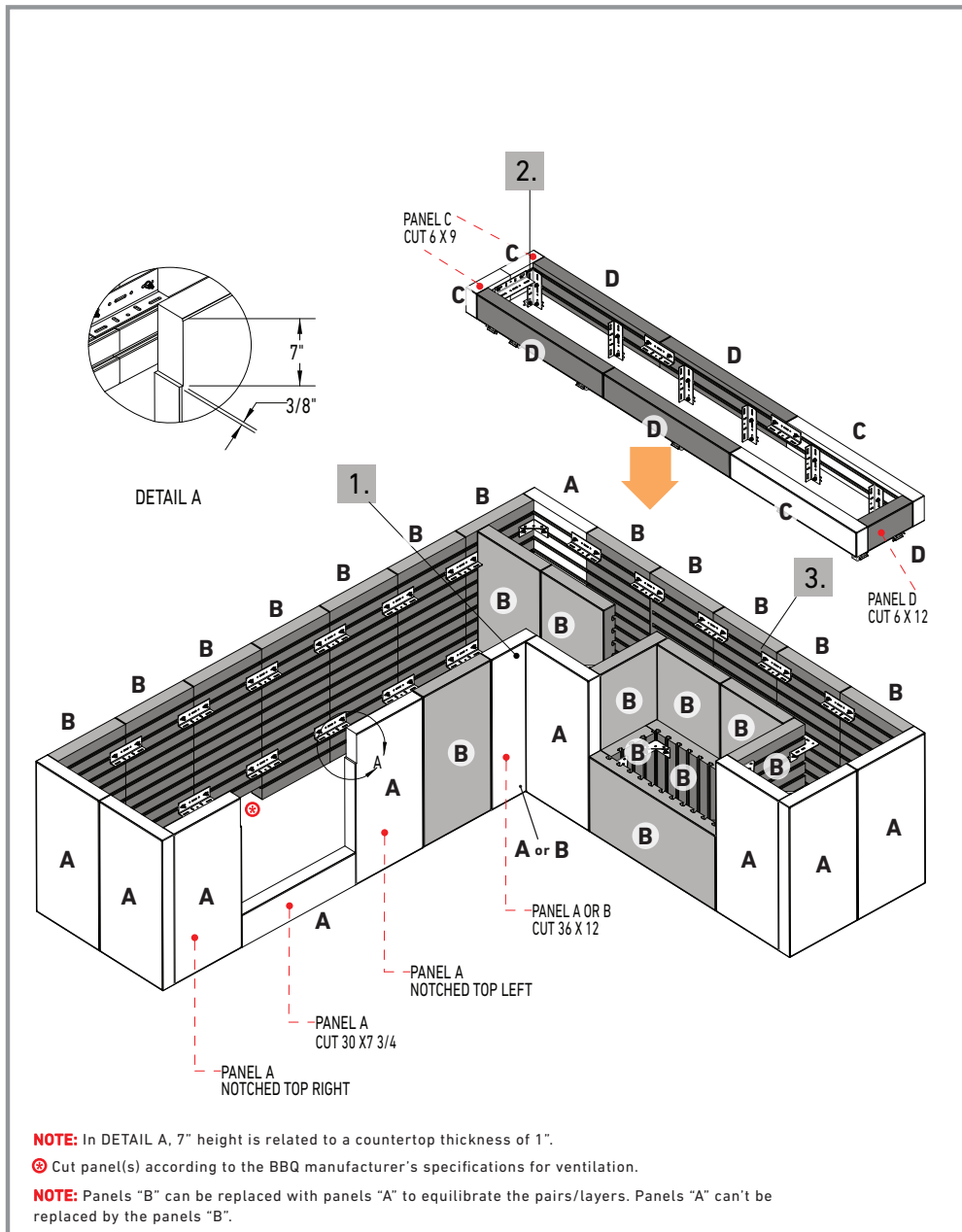

**IMPORTANT:** It is recommended to follow the BBQ manufacturer's specifications for ventilation and clearances. Belgard is not responsible for the conformity of connections, clearances and ventilation. BBQ, countertop and accessories are not included.

# 10. COUNTER & BAR

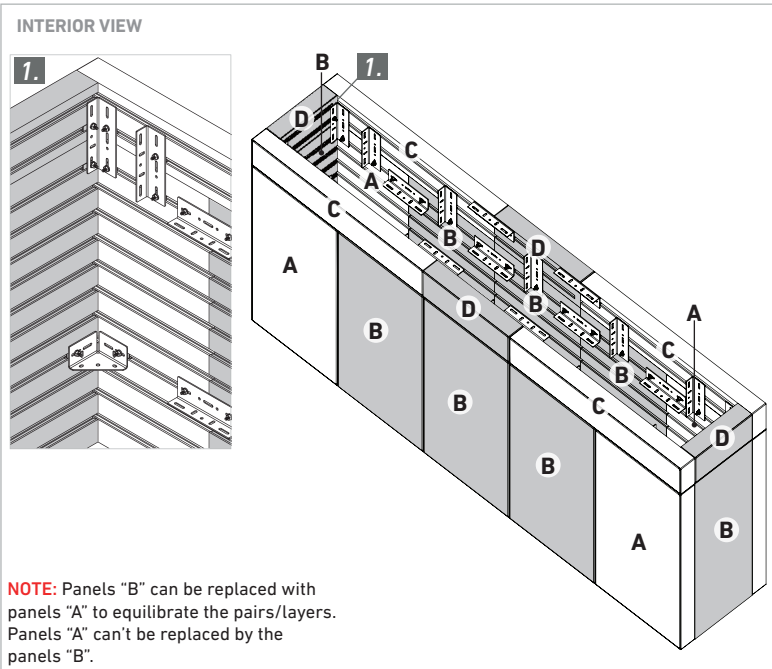

**REQUIRED PANELS**

	<b>4x</b>
	<b>8x</b>
	<b>4x</b>
	<b>3x</b>

**IMPORTANT:** 18 x 36 panels are sold in pair/layer or in full pallet only. 6 x 36 panels are sold per unit or in layer or in full pallet.

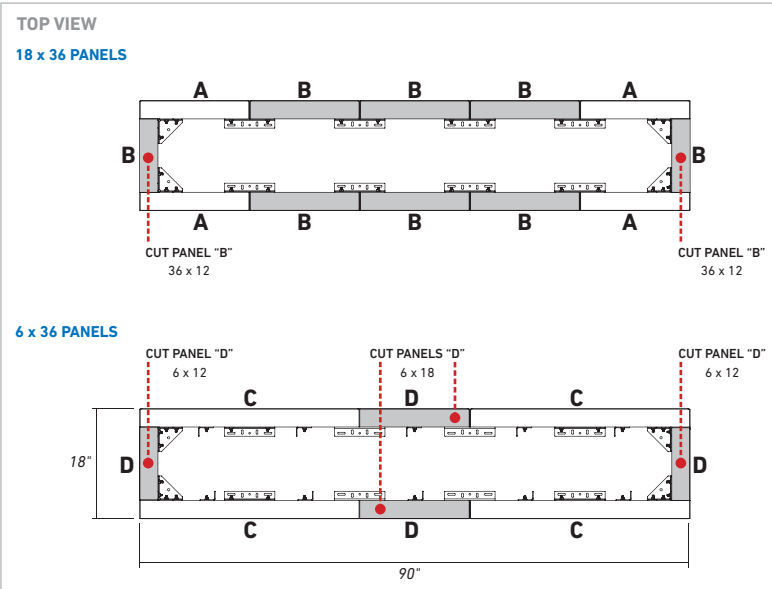
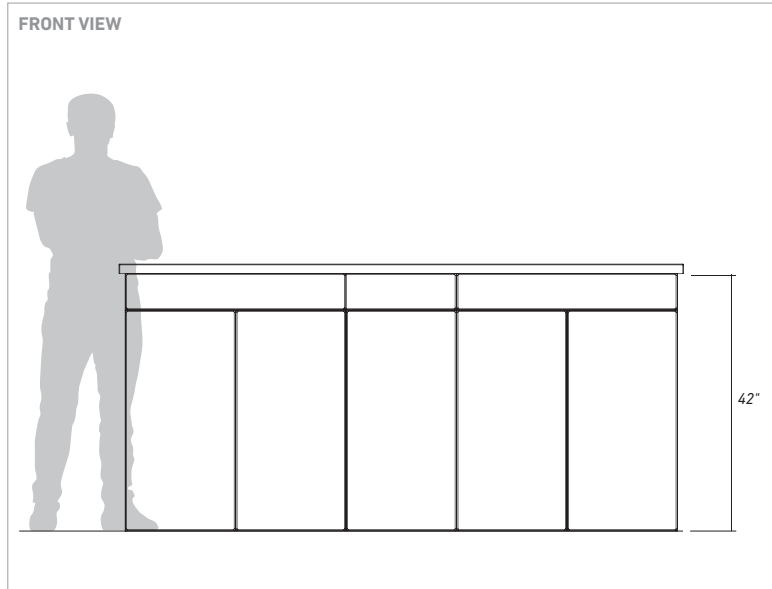

**REQUIRED HARDWARE**

	<b>76x</b>
	<b>34x</b>
	<b>4x</b>
	<b>0x</b>
	<b>0x</b>

**TOTAL WEIGHT (PANELS & HARDWARE) 1968 Lbs**

# 11. LARGE COUNTER



INTERIOR VIEW

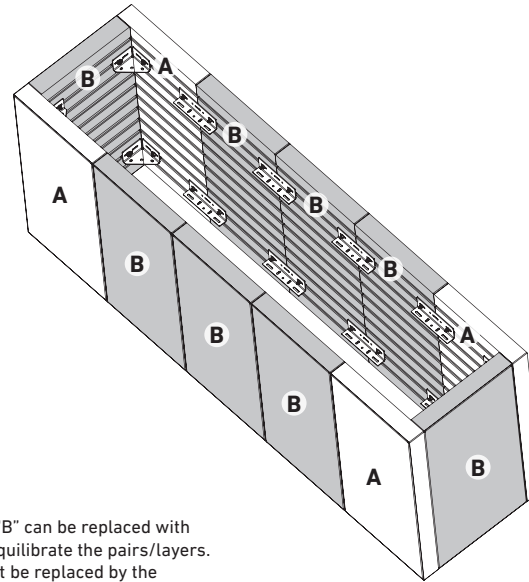

**NOTE:** Panels "B" can be replaced with panels "A" to equilibrate the pairs/layers. Panels "A" can't be replaced by the panels "B".

## REQUIRED PANELS

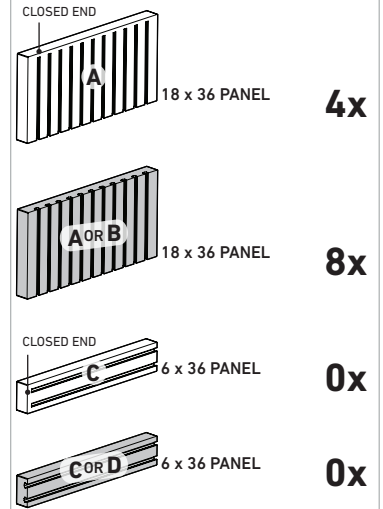

**IMPORTANT:** 18 x 36 panels are sold in pair/layer or in full pallet only. 6 x 36 panels are sold per unit or in layer or in full pallet.

FRONT VIEW

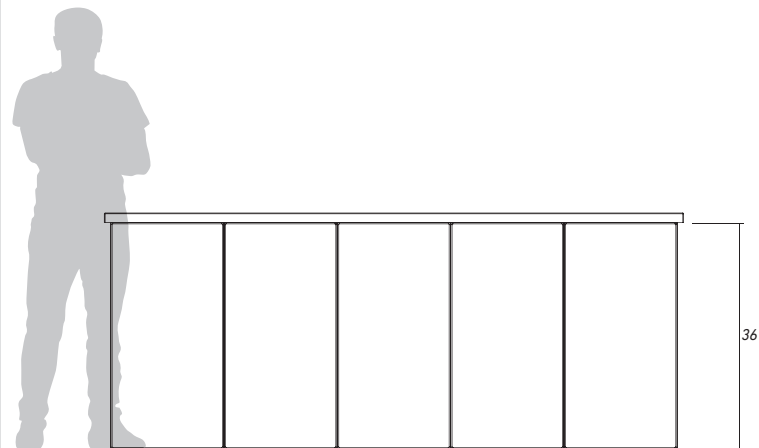

TOP VIEW

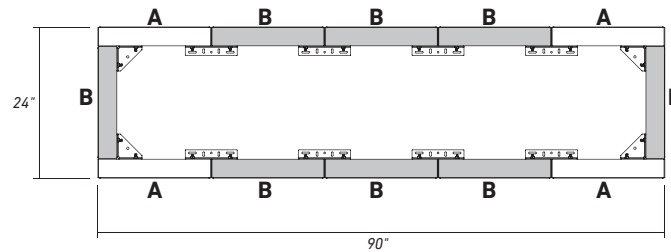

## REQUIRED HARDWARE

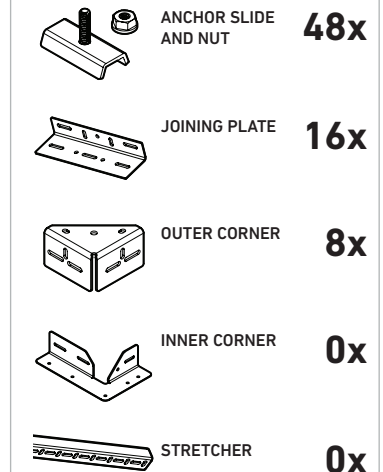

**TOTAL WEIGHT (PANELS & HARDWARE) 1815 Lbs**



# 12. LUXURY COUNTER & BAR





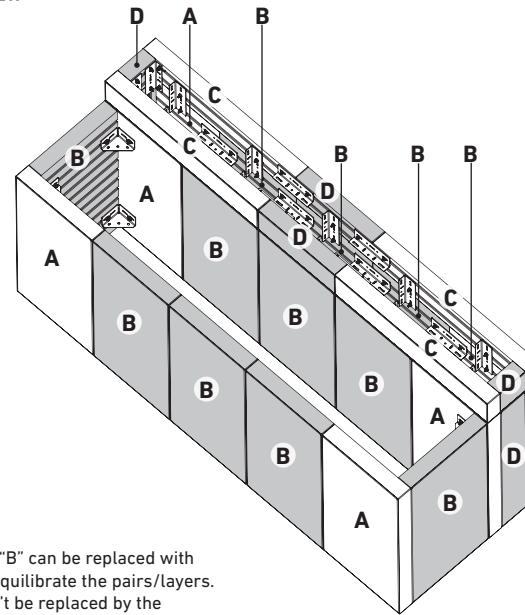

INTERIOR VIEW

For more details see next page

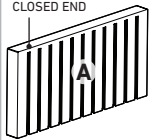

**NOTE:** Panels "B" can be replaced with panels "A" to equilibrate the pairs/layers. Panels "A" can't be replaced by the panels "B".

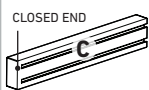
## REQUIRED PANELS

- 
**6x**
- 
**11x**
- 
**4x**
- 
**5x**

**IMPORTANT:** 18 x 36 panels are sold in pair/layer or in full pallet only. 6 x 36 panels are sold per unit or in layer or in full pallet.

FRONT VIEW

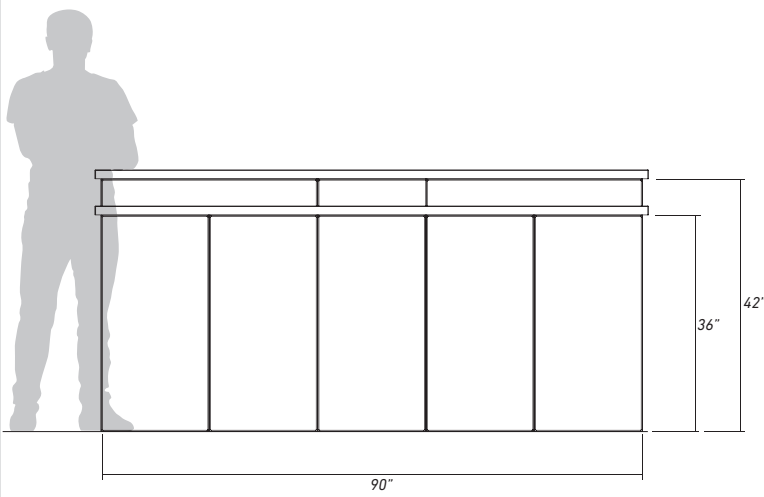

TOP VIEW

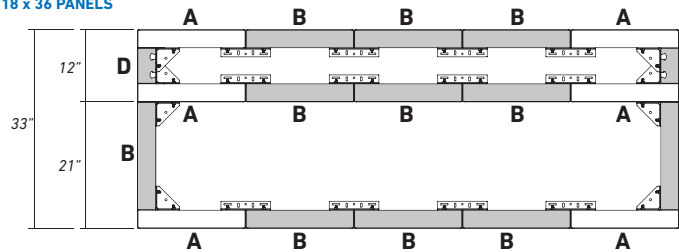

18 x 36 PANELS

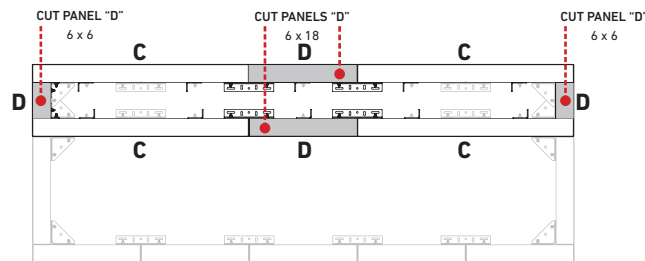

6 x 36 PANELS

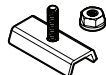
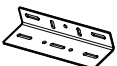
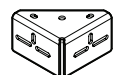

## REQUIRED HARDWARE

- 
**108x**
- 
**42x**
- 
**12x**
- 
**0x**
- 
**0x**

**TOTAL WEIGHT (PANELS & HARDWARE) 2934 Lbs**

# 12. LUXURY COUNTER & BAR

EXPLODED VIEW

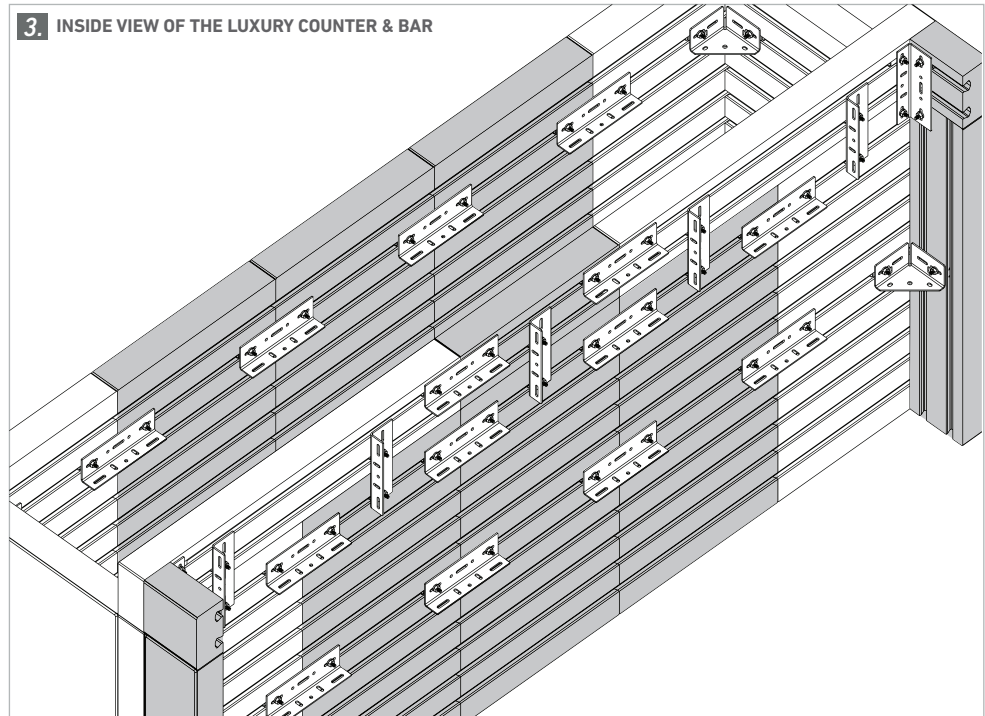
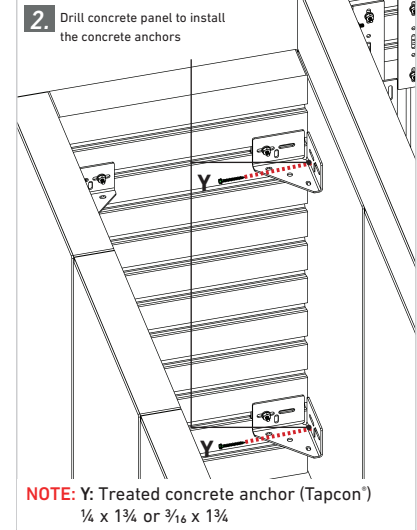
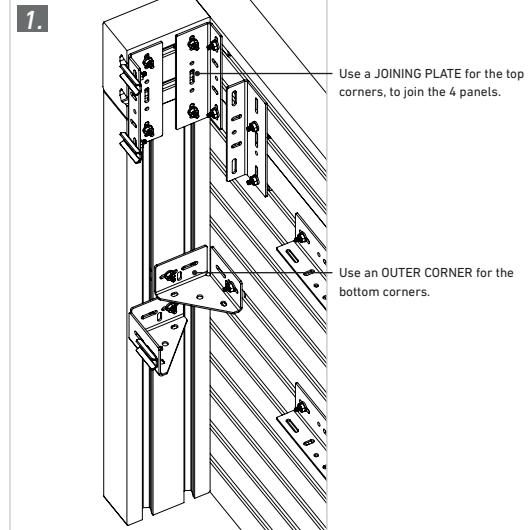
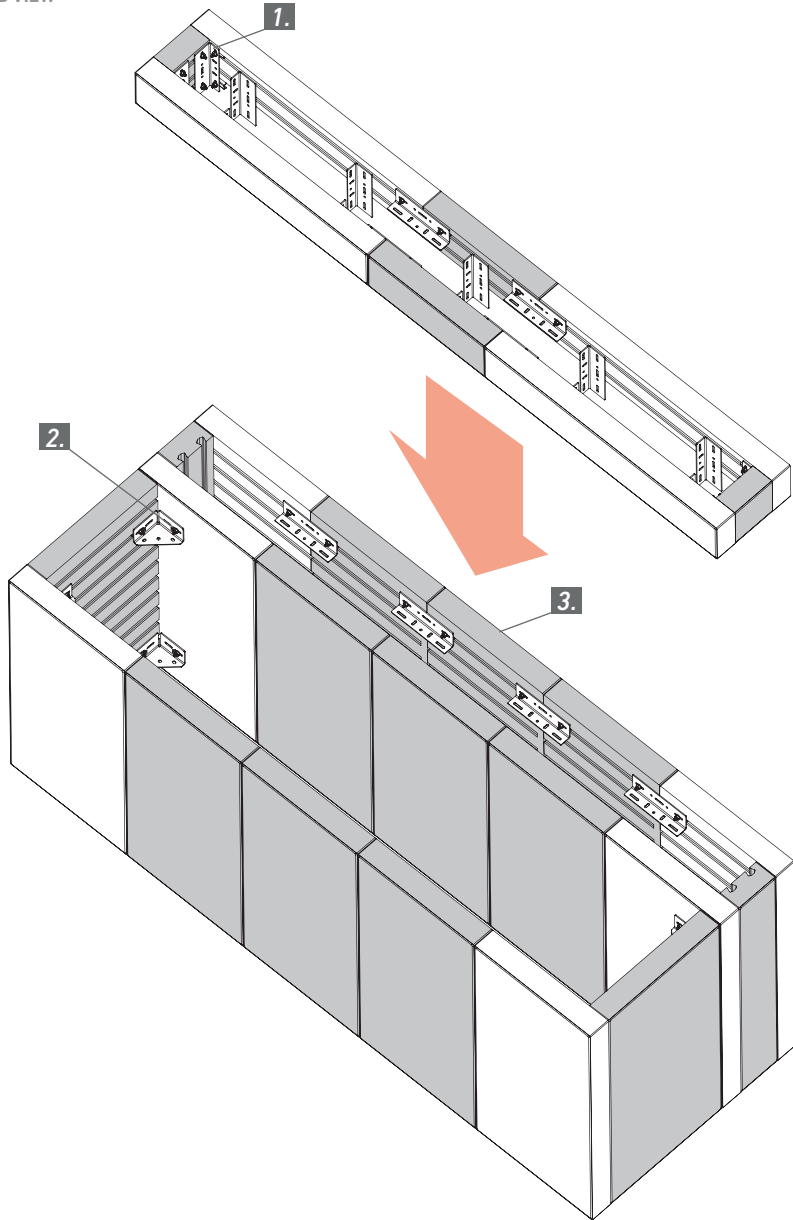

# 13. RECESSED WOOD FIRE PIT



INTERIOR VIEW

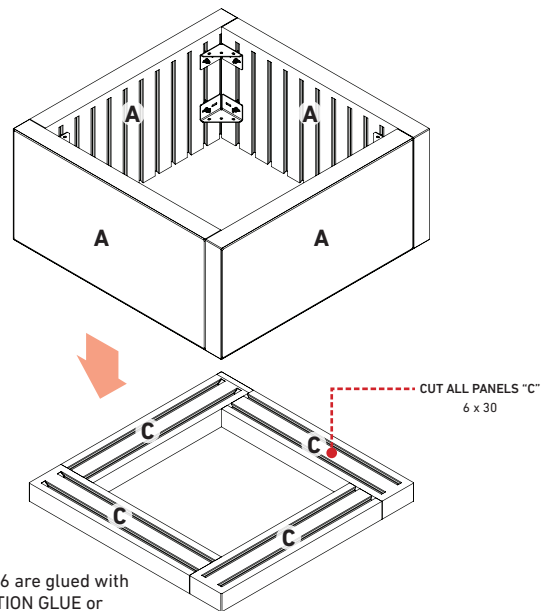

**NOTE:** The panels 18 x 36 are glued with 6 x 36 using CONSTRUCTION GLUE or STRUCTURE BOND

## REQUIRED PANELS

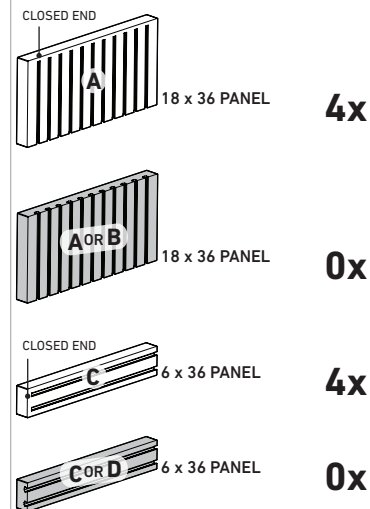

**IMPORTANT:** 18 x 36 panels are sold in pair/layer or in full pallet only. 6 x 36 panels are sold per unit or in layer or in full pallet.

FRONT VIEW

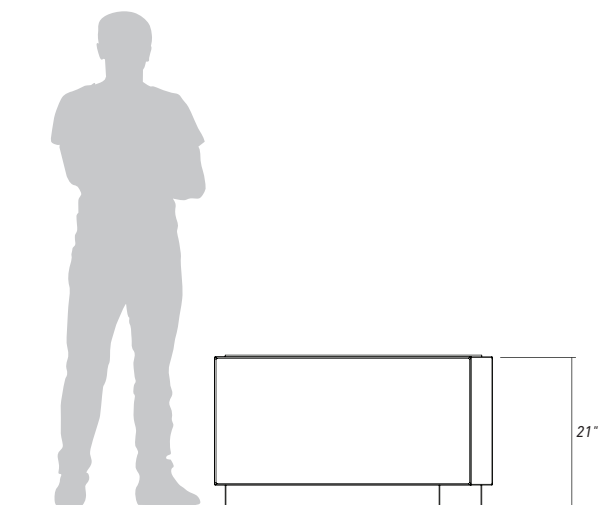

TOP VIEW

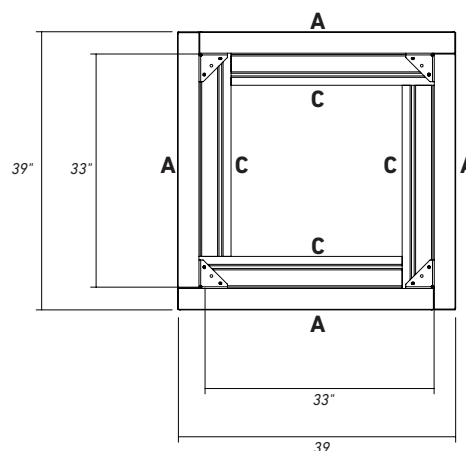

## REQUIRED HARDWARE

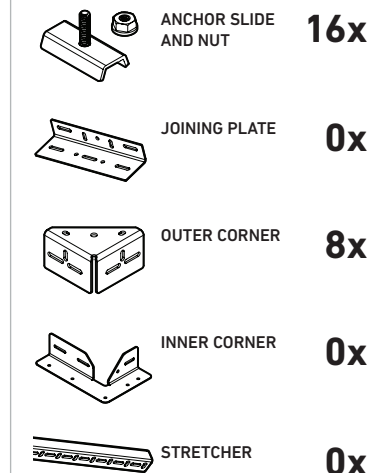

**IMPORTANT:** It is recommended to follow the burner manufacturer's specifications for ventilation. Belgard is not responsible for the conformity of connections, clearances and ventilation. Metal liner plate and accessories are not included.

**TOTAL WEIGHT (PANELS & HARDWARE) 772 Lbs**

# 14. RECESSED GAS FIRE PIT



## INTERIOR VIEW

The 30 x 30 burner pan is sitting directly on the ARTFORMS hardware, on the corner's brackets.

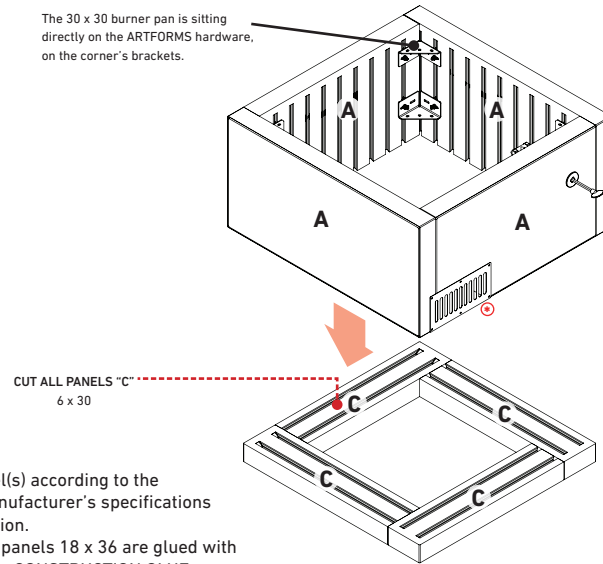

Ⓢ Cut panel(s) according to the burner manufacturer's specifications for ventilation.

**NOTE:** The panels 18 x 36 are glued with 6 x 36 using CONSTRUCTION GLUE or STRUCTURE BOND

## REQUIRED PANELS

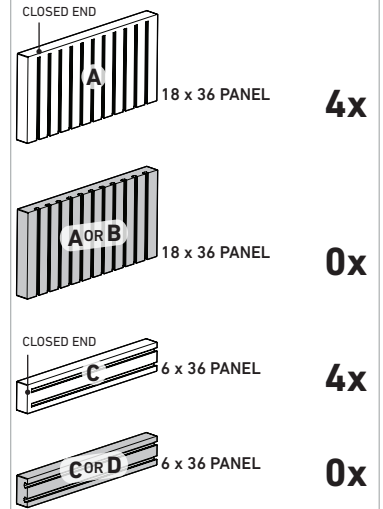

**IMPORTANT:** 18 x 36 panels are sold in pair/layer or in full pallet only. 6 x 36 panels are sold per unit or in layer or in full pallet.

## FRONT VIEW

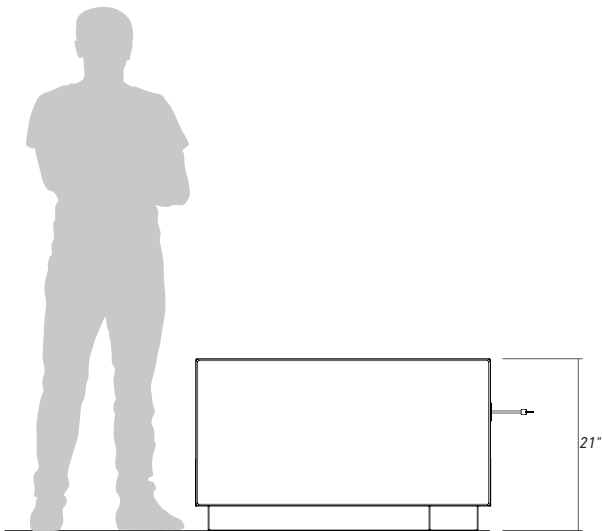

## TOP VIEW

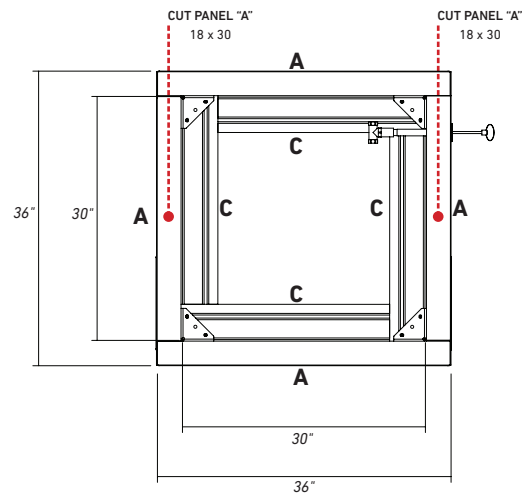

## REQUIRED HARDWARE

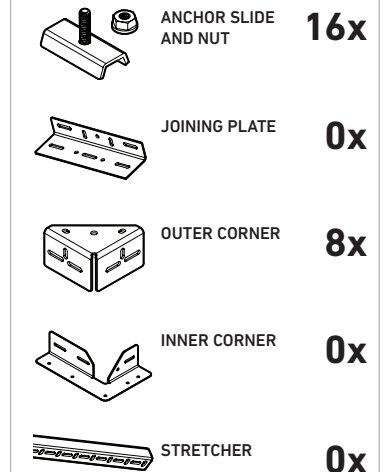

**IMPORTANT:** It is recommended to follow the burner manufacturer's specifications for ventilation. Belgard is not responsible for the conformity of connections, clearances and ventilation. Burner pan and accessories are not included.

# 15. GAS FIRE PIT





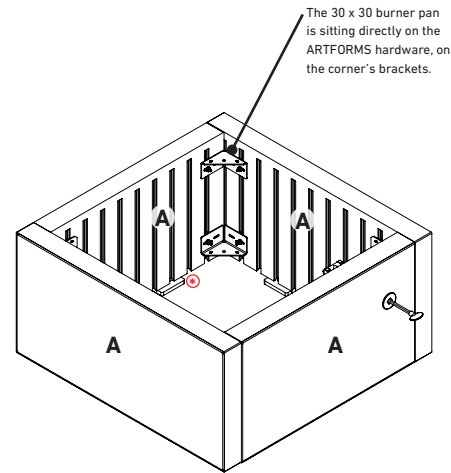

INTERIOR VIEW

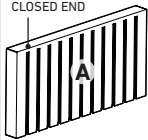

⊕ Add 0.5" thick PLASTIC SHIMS for ventilation

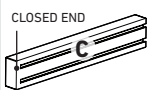
## REQUIRED PANELS

-  18 x 36 PANEL **4x**
-  18 x 36 PANEL **0x**
-  6 x 36 PANEL **0x**
-  6 x 36 PANEL **0x**

**IMPORTANT:** 18 x 36 panels are sold in pair/layer or in full pallet only. 6 x 36 panels are sold per unit or in layer or in full pallet.

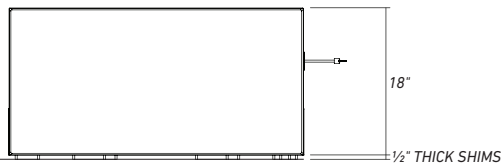

FRONT VIEW

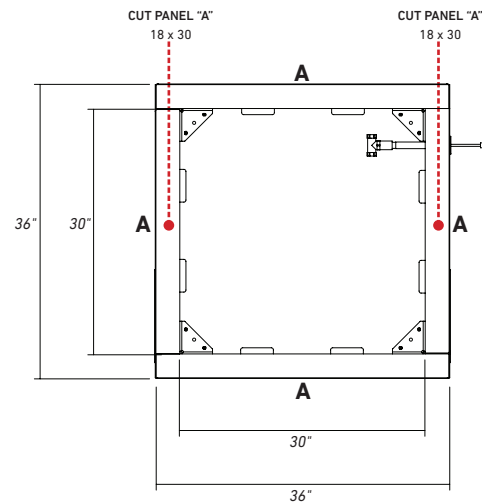

TOP VIEW

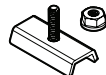
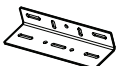
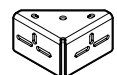

## REQUIRED HARDWARE

-  ANCHOR SLIDE AND NUT **16x**
-  JOINING PLATE **0x**
-  OUTER CORNER **8x**
-  INNER CORNER **0x**
-  STRETCHER **0x**

**IMPORTANT:** It is recommended to follow the firekit manufacturer's specifications for ventilation. Belgard is not responsible for the conformity of connections, clearances and ventilation. Burner pan and accessories are not included.

**TOTAL WEIGHT (PANELS & HARDWARE)** **535 Lbs**

# 16. RECESSED RECTANGULAR GAS FIRE PIT



## INTERIOR VIEW

The panels on the top are glued using CONSTRUCTION GLUE or STRUCTURE BOND

The 17 x 46 burner pan is sitting directly on the ARTFORMS hardware, on the joinings brackets.

Ⓢ Cut panel(s) according to the burner manufacturer's specifications for ventilation.

**NOTE:** The panels 18 x 36 are glued with 6 x 36 using CONSTRUCTION GLUE or STRUCTURE BOND

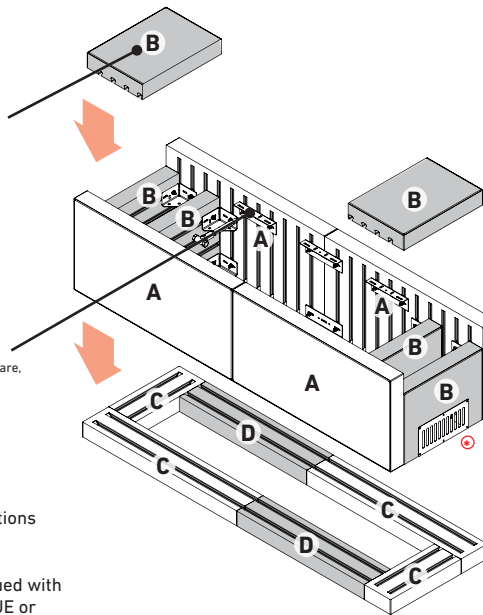

## REQUIRED PANELS

	18 x 36 PANEL	<b>4x</b>
	18 x 36 PANEL	<b>3x</b>
	6 x 36 PANEL	<b>4x</b>
	6 x 36 PANEL	<b>2x</b>

**IMPORTANT:** 18 x 36 panels are sold in pair/layer or in full pallet only. 6 x 36 panels are sold per unit or in layer or in full pallet.

## FRONT VIEW

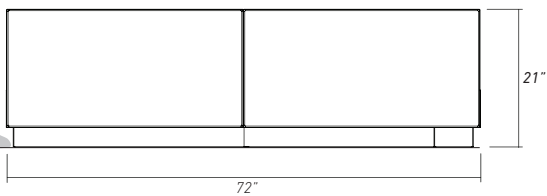

## TOP VIEW

### WITHOUT TOP PANELS

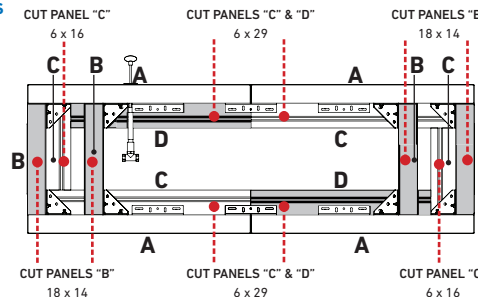

### WITH TOP PANELS

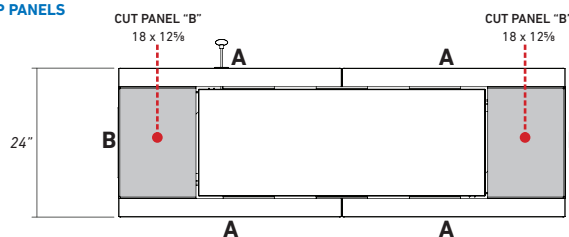

## REQUIRED HARDWARE

	ANCHOR SLIDE AND NUT	<b>48x</b>
	JOINING PLATE	<b>8x</b>
	OUTER CORNER	<b>16x</b>
	INNER CORNER	<b>0x</b>
	STRETCHER	<b>0x</b>

**IMPORTANT:** It is recommended to follow the firekit manufacturer's specifications for ventilation. Belgard is not responsible for the conformity of connections, clearances and ventilation. Burner pan and accessories are not included.

**TOTAL WEIGHT (PANELS & HARDWARE) 1130 Lbs**

# 17. RECTANGULAR GAS FIRE PIT



## INTERIOR VIEW

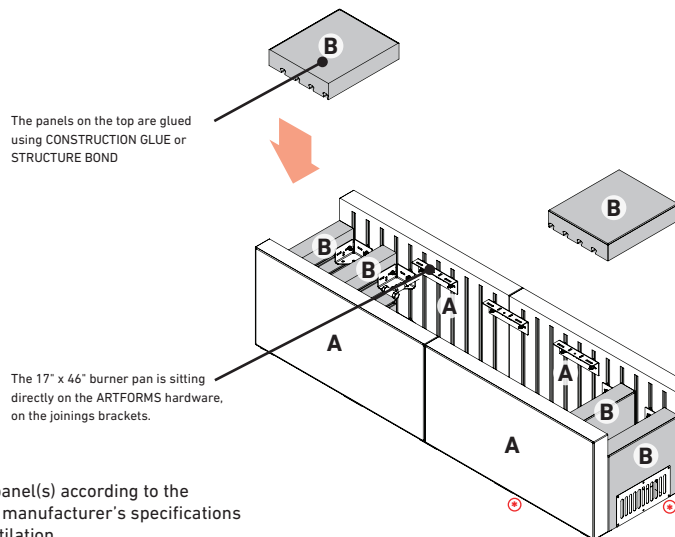

- Ⓢ Cut panel(s) according to the burner manufacturer's specifications for ventilation.
- Ⓢ Add 0.5" thick PLASTIC SHIMS for ventilation

## REQUIRED PANELS

CLOSED END 	18 x 36 PANEL	<b>4x</b>
	18 x 36 PANEL	<b>3x</b>
CLOSED END 	6 x 36 PANEL	<b>0x</b>
	6 x 36 PANEL	<b>0x</b>

**IMPORTANT:** 18 x 36 panels are sold in pair/layer or in full pallet only. 6 x 36 panels are sold per unit or in layer or in full pallet.

## FRONT VIEW

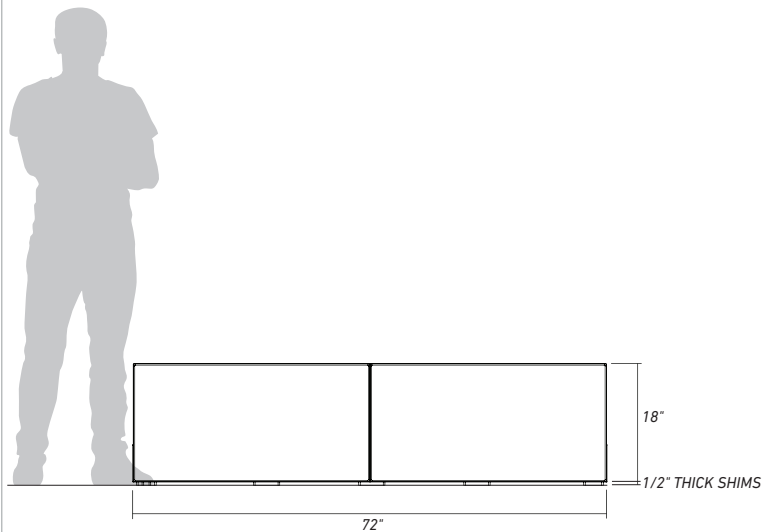

## TOP VIEW

### WITHOUT TOP LAYER

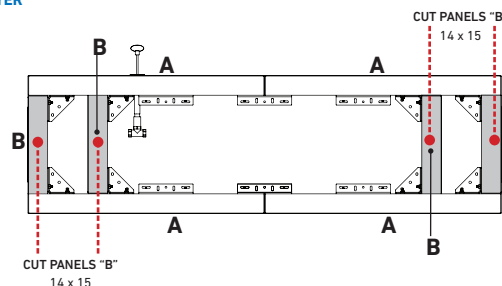

### WITH TOP LAYER

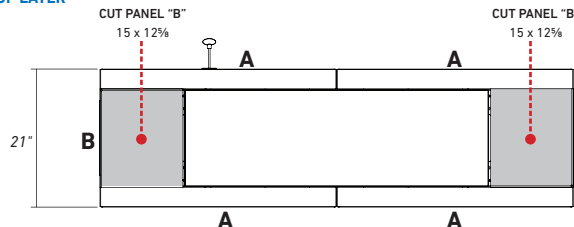

## REQUIRED HARDWARE

	ANCHOR SLIDE AND NUT	<b>48x</b>
	JOINING PLATE	<b>8x</b>
	OUTER CORNER	<b>16x</b>
	INNER CORNER	<b>0x</b>
	STRETCHER	<b>0x</b>

**TOTAL WEIGHT (PANELS & HARDWARE)** **880 Lbs**

**IMPORTANT:** It is recommended to follow the firekit manufacturer's specifications for ventilation. Belgard is not responsible for the conformity of connections, clearances and ventilation. Burner plate and accessories are not included.

# 18. SQUARE PLANTER



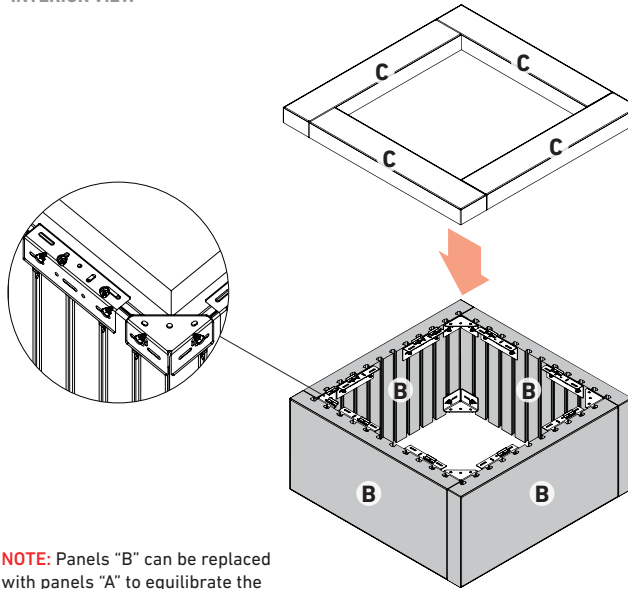

INTERIOR VIEW

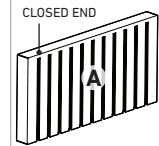
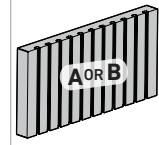
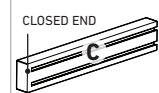

**NOTE:** Panels "B" can be replaced with panels "A" to equilibrate the pairs/layers. Panels "A" can't be replaced by the panels "B".

## REQUIRED PANELS

-  **0x**
-  **4x**
-  **4x**
-  **0x**

**IMPORTANT:** 18 x 36 panels are sold in pair/layer or in full pallet only. 6 x 36 panels are sold per unit or in layer or in full pallet.

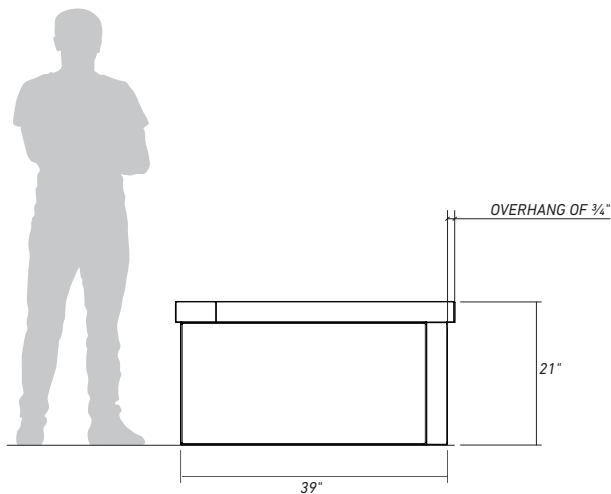

FRONT VIEW

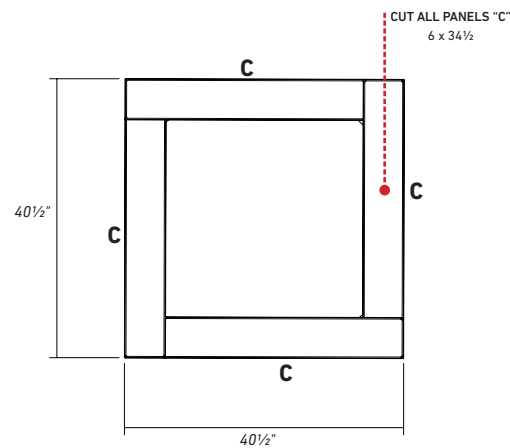

TOP VIEW

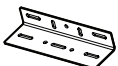
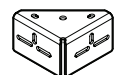
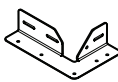

## REQUIRED HARDWARE

-  **40x**
-  **8x**
-  **8x**
-  **0x**
-  **0x**

**IMPORTANT:** Refer to page 23 of the ARTFORMS INSTALLATION GUIDE about the installation of geotextile in planter box. Contact experts/engineers to validate the base preparation, the drainage, the plants & roots growth/management.

**TOTAL WEIGHT (PANELS & HARDWARE)** **804 Lbs**



# 19. RECTANGULAR PLANTER



INTERIOR VIEW

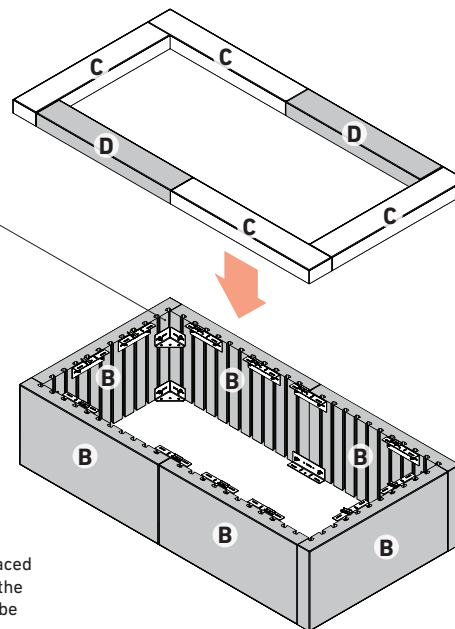
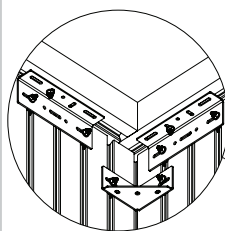

**NOTE:** Panels "B" can be replaced with panels "A" to equilibrate the pairs/layers. Panels "A" can't be replaced by the panels "B".

## REQUIRED PANELS

	<b>0x</b>
	<b>6x</b>
	<b>4x</b>
	<b>2x</b>

**IMPORTANT:** 18 x 36 panels are sold in pair/layer or in full pallet only. 6 x 36 panels are sold per unit or in layer or in full pallet.

FRONT VIEW

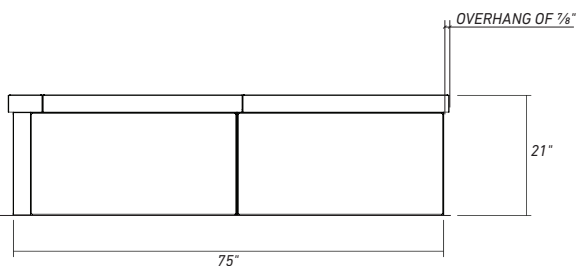

TOP VIEW

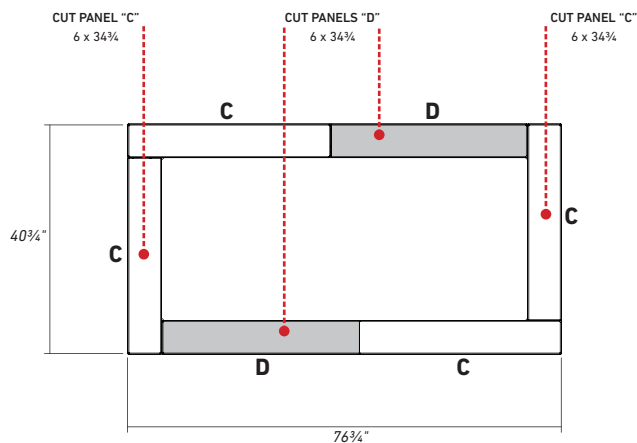

## REQUIRED HARDWARE

	<b>56x</b>
	<b>14x</b>
	<b>8x</b>
	<b>0x</b>
	<b>0x</b>

**IMPORTANT:** Refer to page 23 of the ARTFORMS INSTALLATION GUIDE about the installation of geotextile in planter box. Contact experts/engineers to validate the base preparation, the drainage, the plants & roots growth/management.

**TOTAL WEIGHT (PANELS & HARDWARE)** **1209 Lbs**

# 20. VERTICAL PLANTER

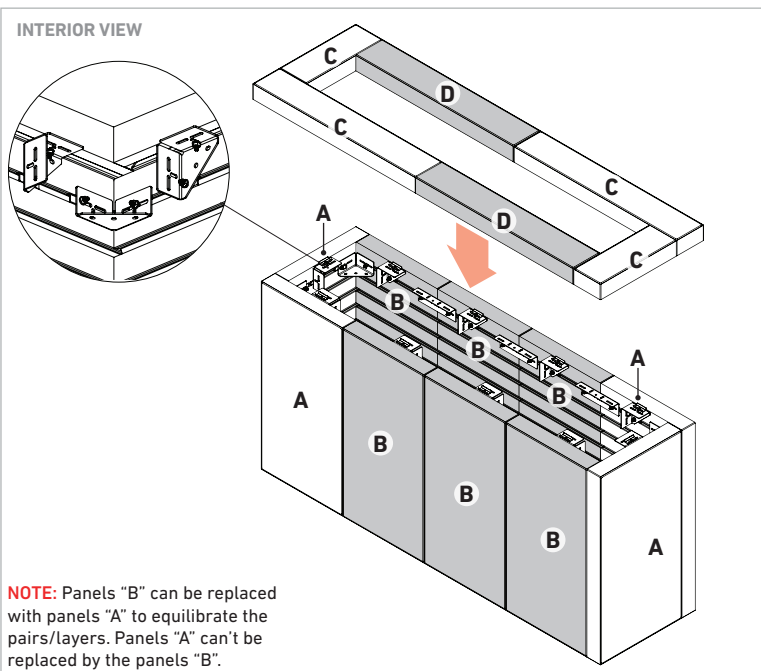

**REQUIRED PANELS**

	18 x 36 PANEL	<b>4x</b>
	18 x 36 PANEL	<b>6x</b>
	6 x 36 PANEL	<b>4x</b>
	6 x 36 PANEL	<b>2x</b>

**IMPORTANT:** 18 x 36 panels are sold in pair/layer or in full pallet only. 6 x 36 panels are sold per unit or in layer or in full pallet.

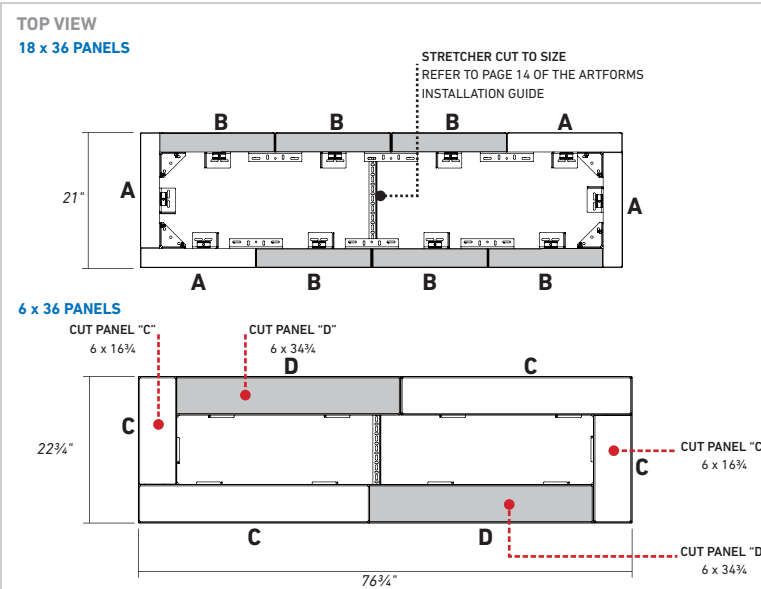
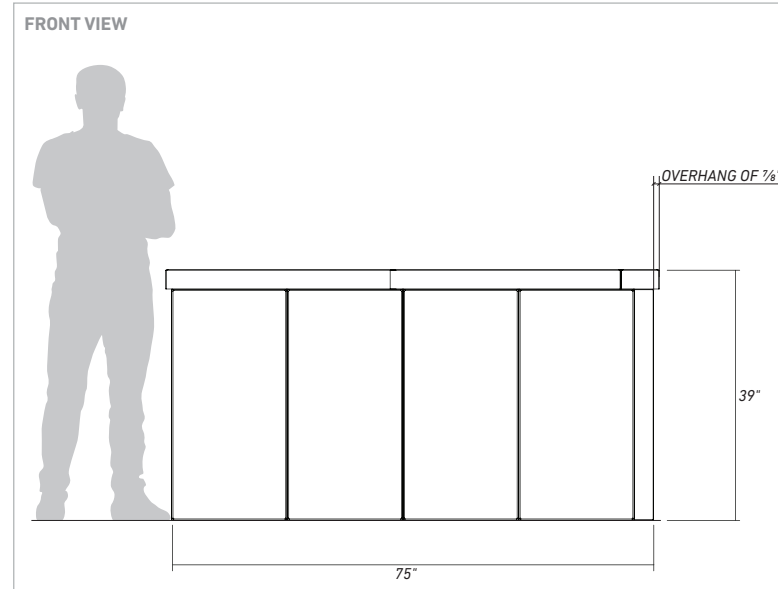

**REQUIRED HARDWARE**

	ANCHOR SLIDE AND NUT	<b>62x</b>
	JOINING PLATE	<b>12x</b>
	OUTER CORNER	<b>18x</b>
	INNER CORNER	<b>0x</b>
	STRETCHER	<b>1x</b>

**IMPORTANT:** Refer to page 23 of the ARTFORMS INSTALLATION GUIDE about the installation of geotextile in planter box. Contact experts/engineers to validate the base preparation, the drainage, the plants & roots growth/management.

**TOTAL WEIGHT (PANELS & HARDWARE)** **1765 Lbs**

# 21. PRIVACY WALL WITH BENCH



INTERIOR VIEW

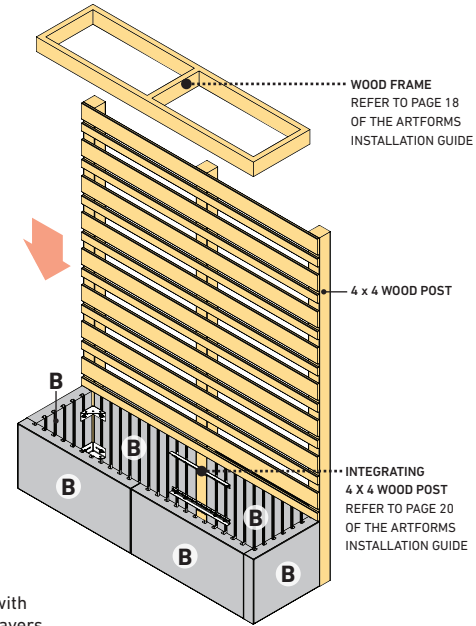
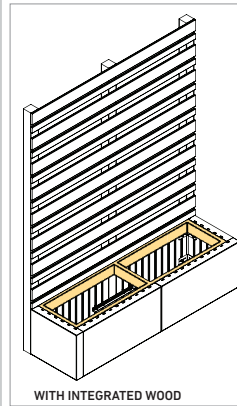

**NOTE:** Panels "B" can be replaced with panels "A" to equilibrate the pairs/layers.

## REQUIRED PANELS

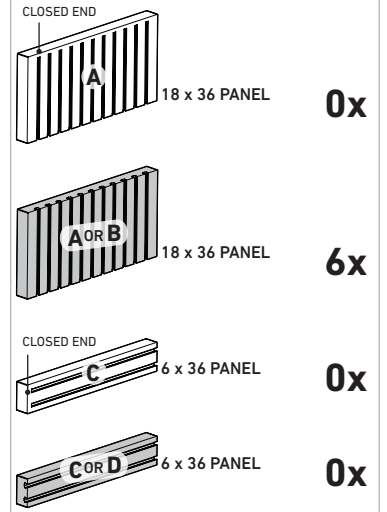

**IMPORTANT:** 18 x 36 panels are sold in pair/layer or in full pallet only. 6 x 36 panels are sold per unit or in layer or in full pallet.

FRONT VIEW

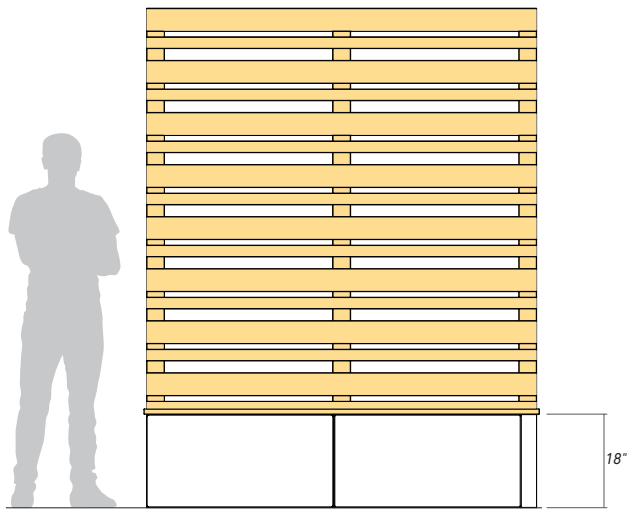

TOP VIEW

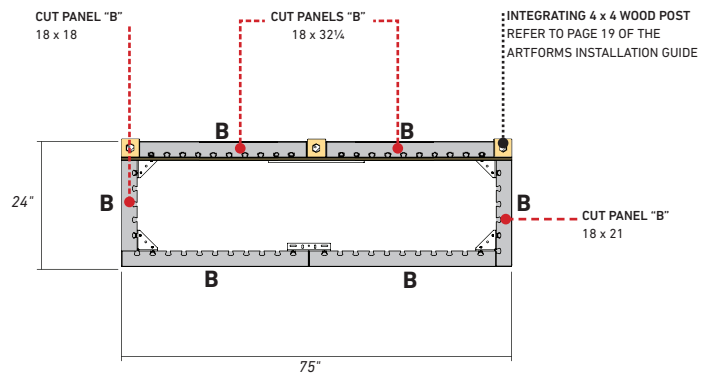

## REQUIRED HARDWARE

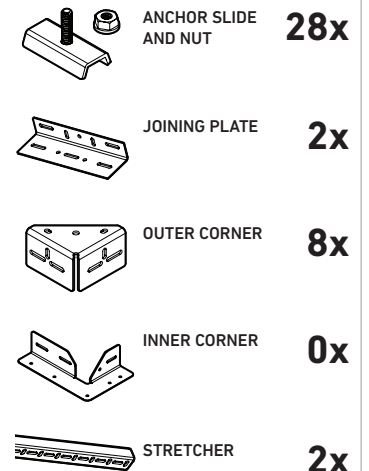

**TOTAL WEIGHT**  
(PANELS & HARDWARE) **740 Lbs**

# 22. PRIVACY WALL WITH PLANTER



INTERIOR VIEW

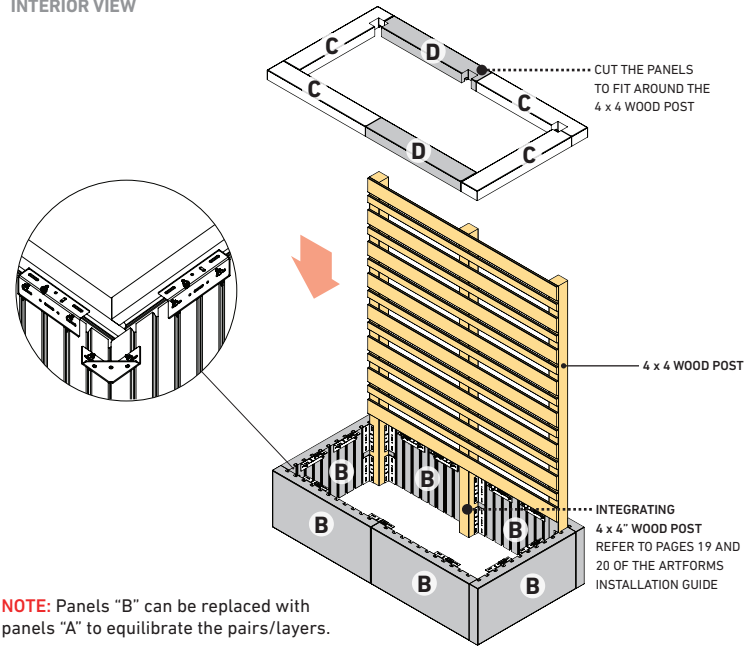

## REQUIRED PANELS

CLOSED END A	18 x 36 PANEL	0x
A OR B	18 x 36 PANEL	6x
CLOSED END C	6 x 36 PANEL	4x
C OR D	6 x 36 PANEL	2x

**IMPORTANT:** 18 x 36 panels are sold in pair/layer or in full pallet only. 6 x 36 panels are sold per unit or in layer or in full pallet.

FRONT VIEW

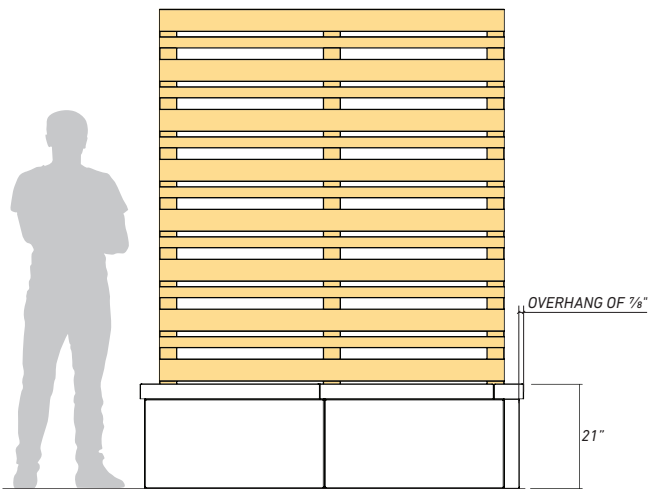

TOP VIEW

18 x 36 PANELS

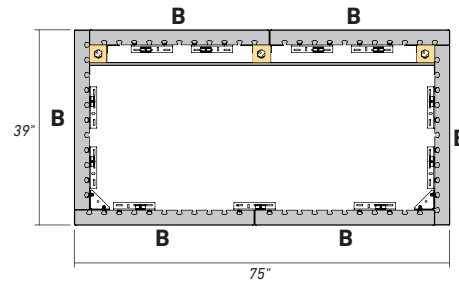

6 x 36 PANELS

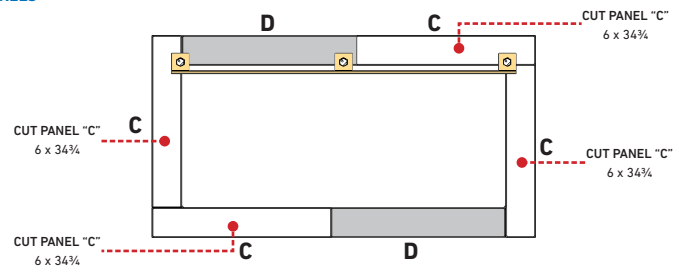

## REQUIRED HARDWARE

ANCHOR SLIDE AND NUT	43x
JOINING PLATE	24x
OUTER CORNER	4x
INNER CORNER	0x
STRETCHER	0x

**IMPORTANT:** Refer to page 23 of the ARTFORMS INSTALLATION GUIDE about the installation of geotextile in planter box. Contact experts/engineers to validate the base preparation, the drainage, the plants & roots growth/management.

**TOTAL WEIGHT (PANELS & HARDWARE)** 1206 Lbs

# PRIVACY WALL WITH VERTICAL PLANTER

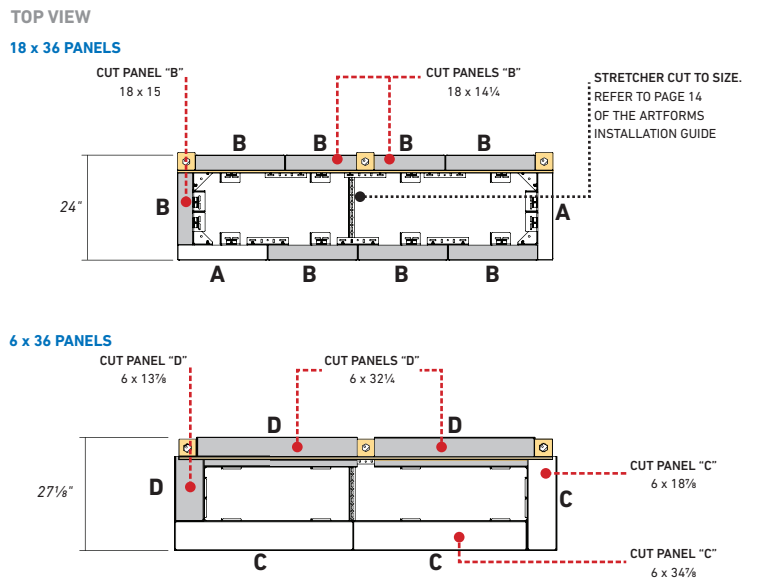
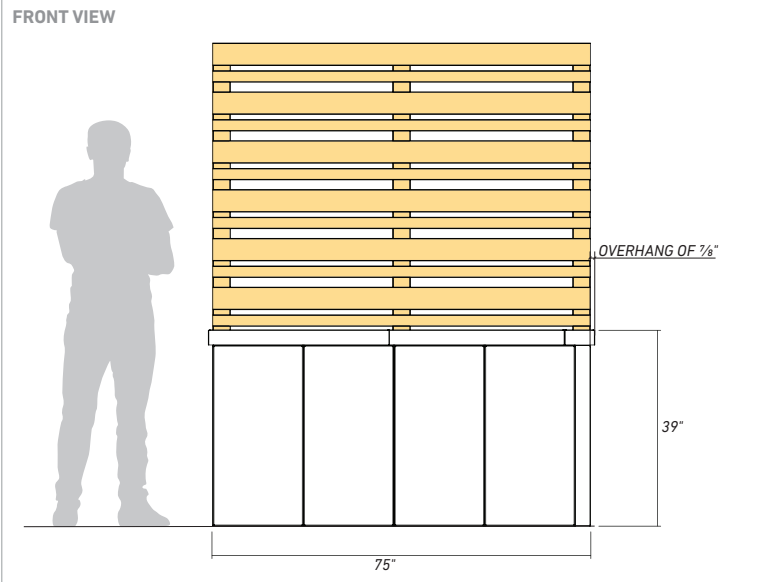
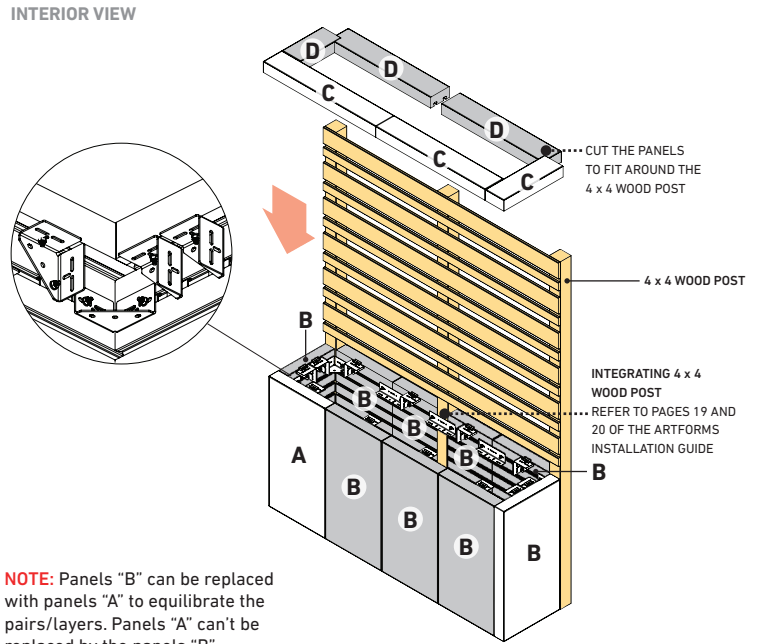

**REQUIRED PANELS**

	18 x 36 PANEL	<b>2x</b>
	18 x 36 PANEL	<b>8x</b>
	6 x 36 PANEL	<b>3x</b>
	6 x 36 PANEL	<b>3x</b>

**IMPORTANT:** 18 x 36 panels are sold in pair/layer or in full pallet only. 6 x 36 panels are sold per unit or in layer or in full pallet.

**REQUIRED HARDWARE**

	ANCHOR SLIDE AND NUT	<b>66x</b>
	JOINING PLATE	<b>12x</b>
	OUTER CORNER	<b>20x</b>
	INNER CORNER	<b>0x</b>
	STRETCHER	<b>1x</b>

**IMPORTANT:** Refer to page 23 of the ARTFORMS INSTALLATION GUIDE about the installation of geotextile in planter box. Contact experts/engineers to validate the base preparation, the drainage, the plants & roots growth/management.

# 24. RAISED GARDEN



## INTERIOR VIEW

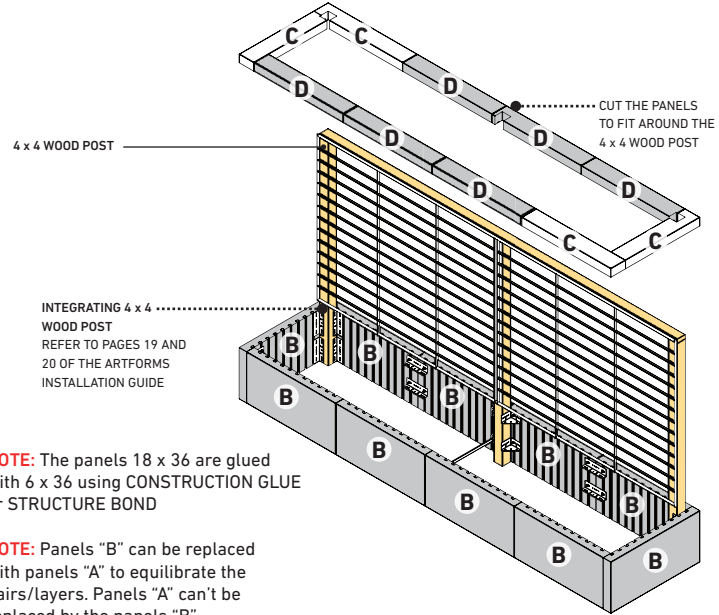

**NOTE:** The panels 18 x 36 are glued with 6 x 36 using CONSTRUCTION GLUE or STRUCTURE BOND

**NOTE:** Panels "B" can be replaced with panels "A" to equilibrate the pairs/layers. Panels "A" can't be replaced by the panels "B".

## REQUIRED PANELS

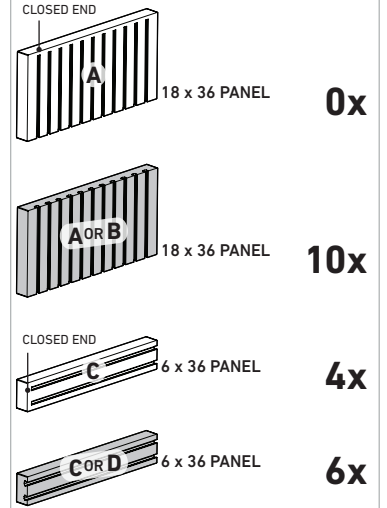

**IMPORTANT:** 18 x 36 panels are sold in pair/layer or in full pallet only. 6 x 36 panels are sold per unit or in layer or in full pallet.

## FRONT VIEW

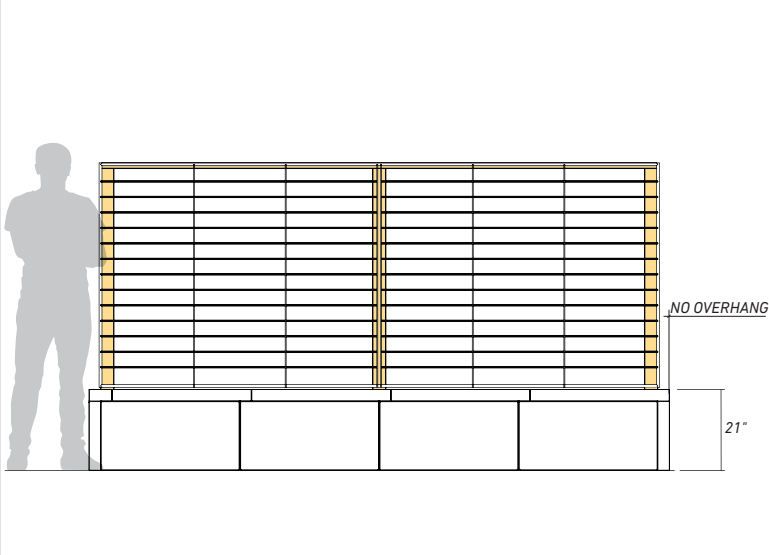

## TOP VIEW

### 18 x 36 PANELS

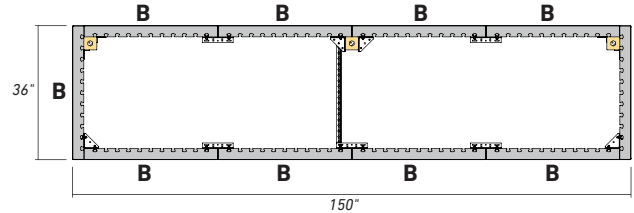

### 6 x 36 PANELS

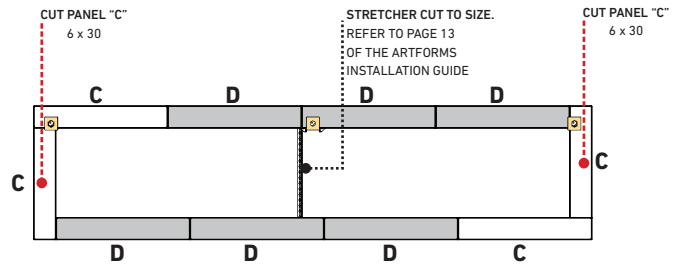

## REQUIRED HARDWARE

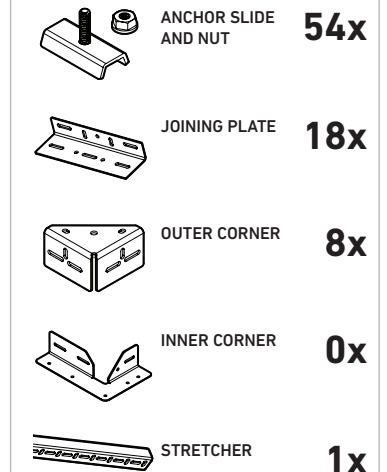

**IMPORTANT:** Refer to page 23 of the ARTFORMS INSTALLATION GUIDE about the installation of geotextile in planter box. Contact experts/engineers to validate the base preparation, the drainage, the plants & roots growth/management.

**TOTAL WEIGHT (PANELS & HARDWARE) 1986 Lbs**

# CORNER MULTILEVEL RAISED GARDEN



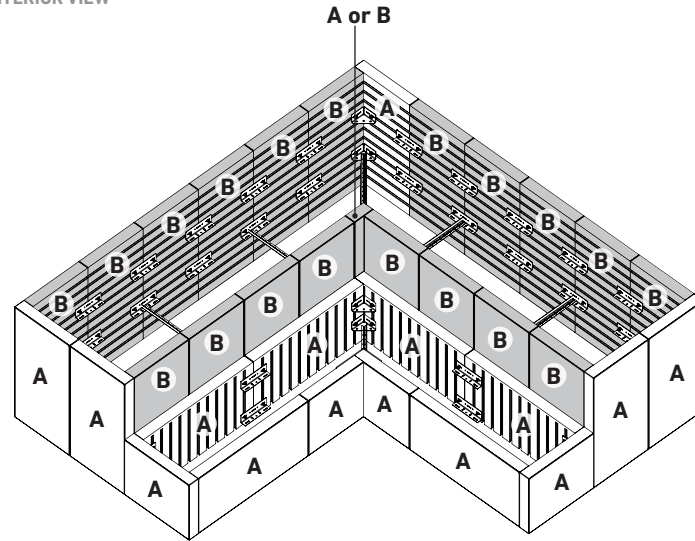

INTERIOR VIEW

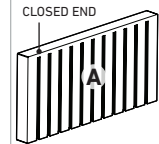
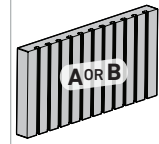
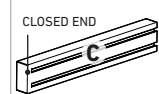

**NOTE:** Panels "B" can be replaced with panels "A" to equilibrate the pairs/layers. Panels "A" can't be replaced by the panels "B".

## REQUIRED PANELS

-  **15x**
-  **20x**
-  **0x**
-  **0x**

**IMPORTANT:** 18 x 36 panels are sold in pair/layer or in full pallet only. 6 x 36 panels are sold per unit or in layer or in full pallet.



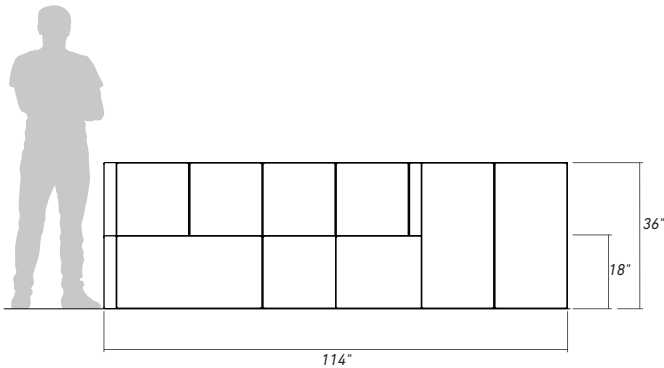

FRONT VIEW

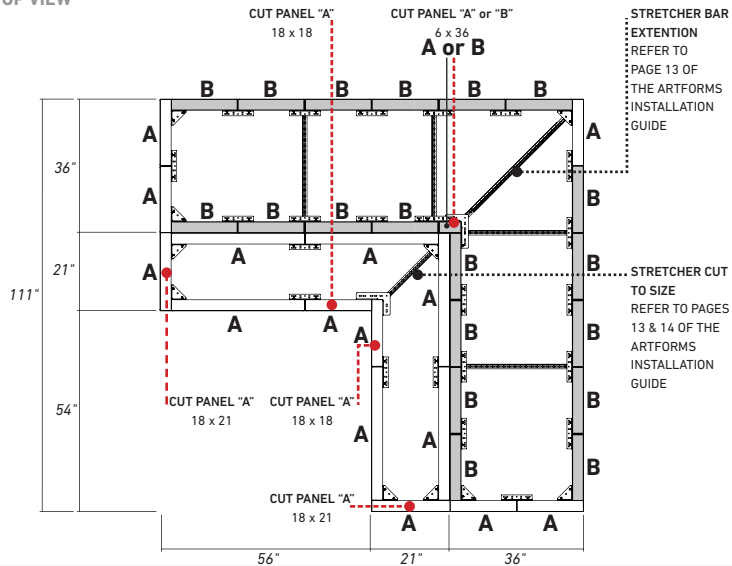

TOP VIEW

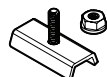
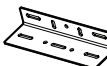

## REQUIRED HARDWARE

-  **153x**
-  **46x**
-  **20x**
-  **4x**
-  **7x**

**IMPORTANT:** Refer to page 23 of the ARTFORMS INSTALLATION GUIDE about the installation of geotextile in planter box. Contact experts/engineers to validate the base preparation, the drainage, the plants & roots growth/management.

**TOTAL WEIGHT (PANELS & HARDWARE)** **4937 Lbs**

# 26. MULTILEVEL RAISED GARDEN



INTERIOR VIEW

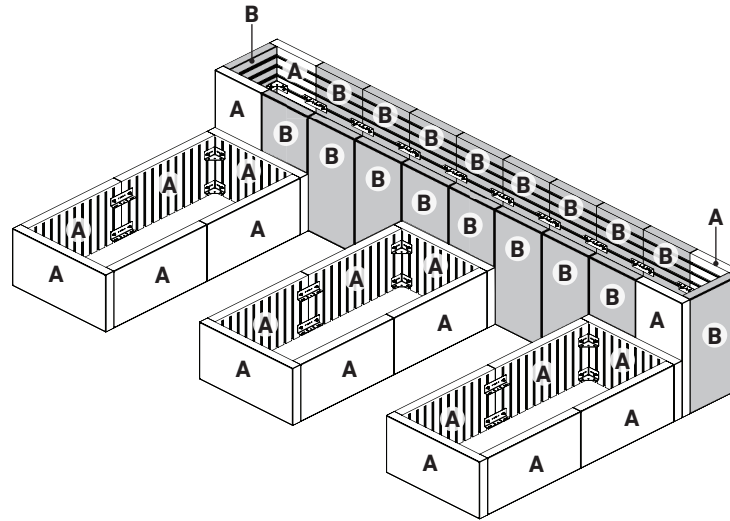

**NOTE:** Panels "B" can be replaced with panels "A" to equilibrate the pairs/layers. Panels "A" can't be replaced by the panels "B".

## REQUIRED PANELS

	18 x 36 PANEL	<b>22x</b>
	18 x 36 PANEL	<b>18x</b>
	6 x 36 PANEL	<b>0x</b>
	6 x 36 PANEL	<b>0x</b>

**IMPORTANT:** 18 x 36 panels are sold in pair/layer or in full pallet only. 6 x 36 panels are sold per unit or in layer or in full pallet.

FRONT VIEW

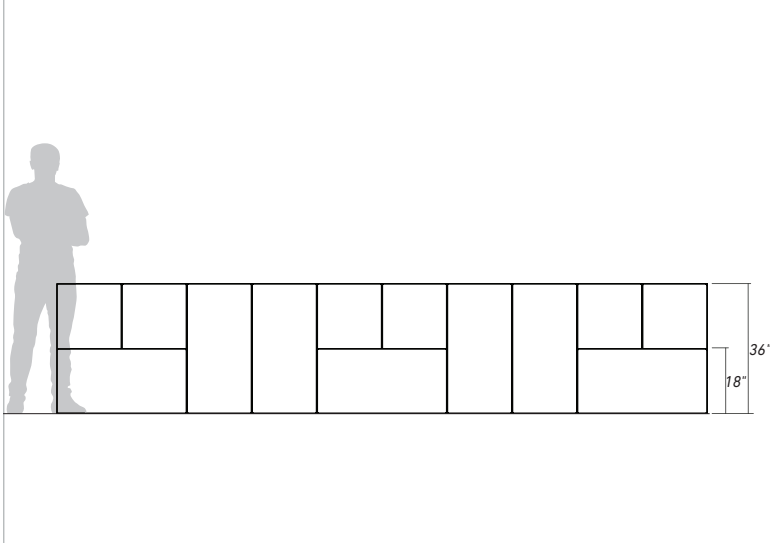

TOP VIEW

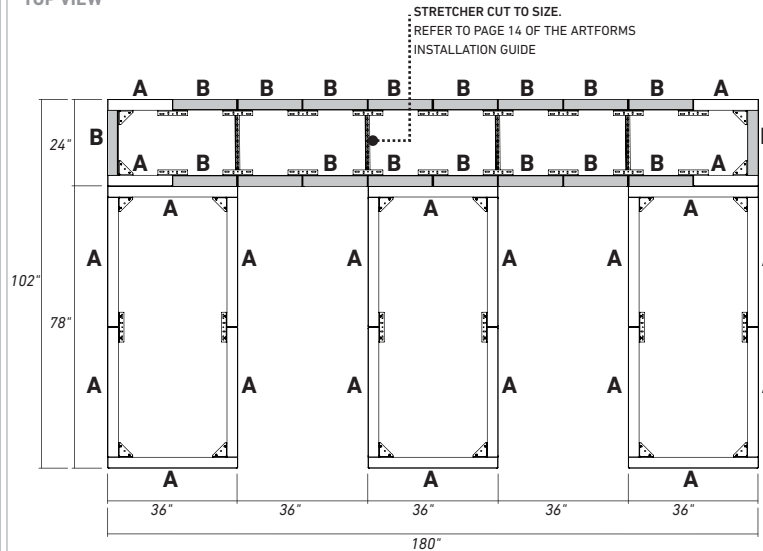

## REQUIRED HARDWARE

	ANCHOR SLIDE AND NUT	<b>168x</b>
	JOINING PLATE	<b>48x</b>
	OUTER CORNER	<b>32x</b>
	INNER CORNER	<b>0x</b>
	STRETCHER	<b>2x</b>

**IMPORTANT:** Refer to page 23 of the ARTFORMS INSTALLATION GUIDE about the installation of geotextile in planter box. Contact experts/engineers to validate the base preparation, the drainage, the plants & roots growth/management.

**TOTAL WEIGHT (PANELS & HARDWARE)** **6058 Lbs**



# FIREPLACE WITH BENCH & WOOD PERGOLA

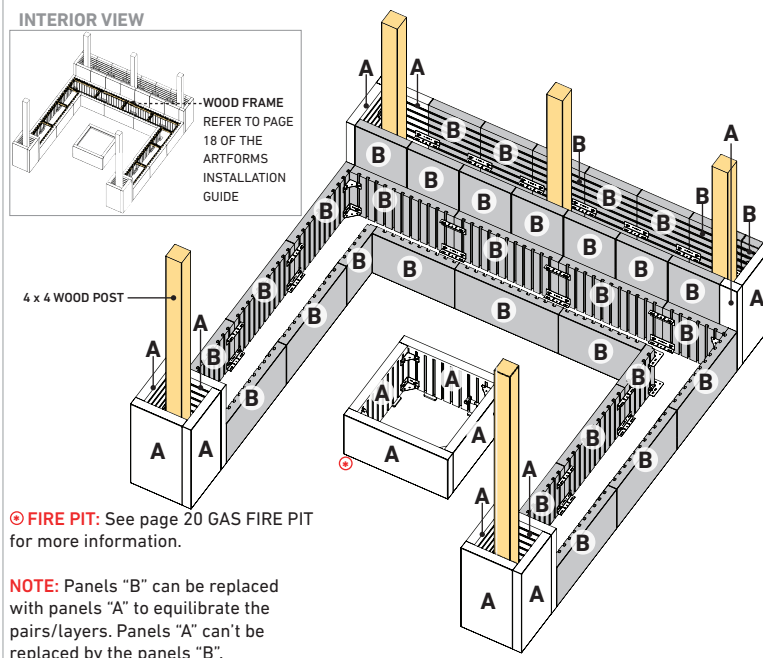

**REQUIRED PANELS**

	18 x 36 PANEL	<b>16x</b>
	18 x 36 PANEL	<b>34x</b>
	6 x 36 PANEL	<b>0x</b>
	6 x 36 PANEL	<b>0x</b>

**IMPORTANT:** 18 x 36 panels are sold in pair/layer or in full pallet only. 6 x 36 panels are sold per unit or in layer or in full pallet.

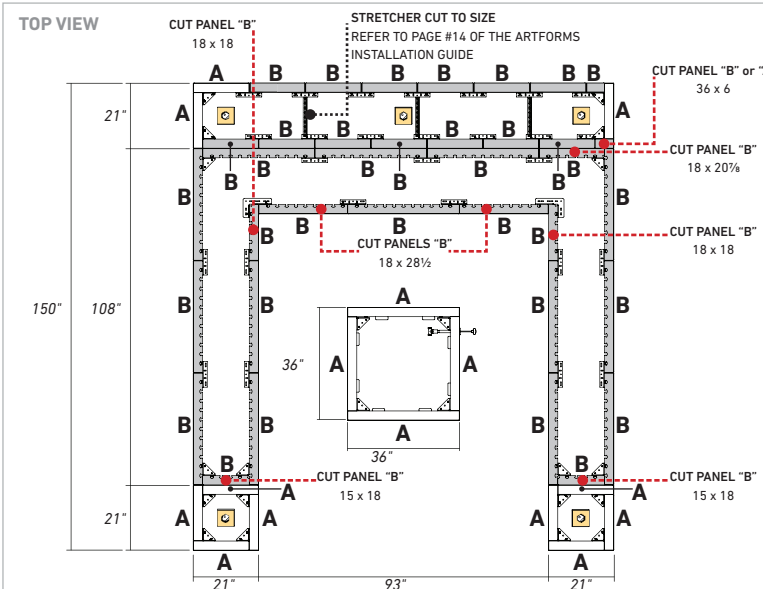
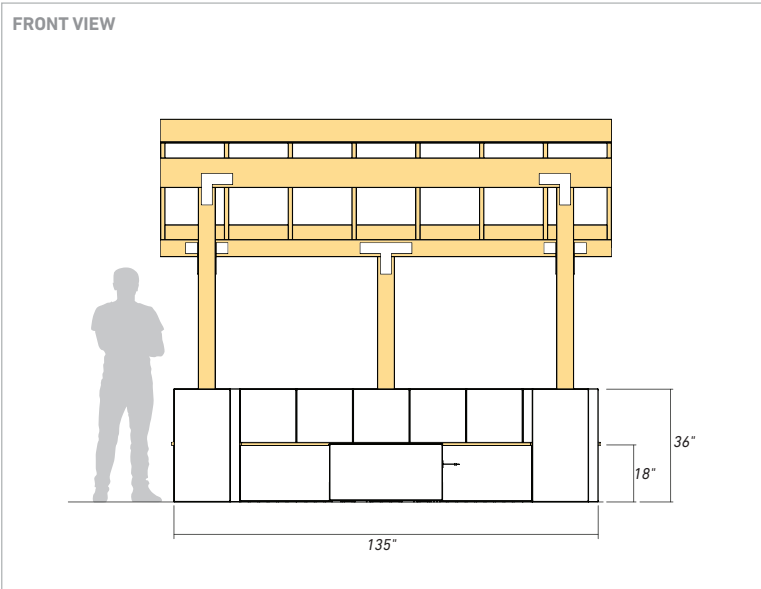

**REQUIRED HARDWARE**

	ANCHOR SLIDE AND NUT	<b>210x</b>
	JOINING PLATE	<b>54x</b>
	OUTER CORNER	<b>44x</b>
	INNER CORNER	<b>4x</b>
	STRETCHER	<b>2x</b>

**IMPORTANT:** Other types of hardware (not included) may be required to make these assemblies (wood screws, concrete anchors, etc.). BELGARD is not responsible for any issue regarding other materials, accessories, other types of hardware, etc. We recommend to consulting an expert/engineer to validate installation of the wood posts of pergola.

**TOTAL WEIGHT (PANELS & HARDWARE)** **2315 Lbs**

# L-SHAPED BENCH & VERTICAL PLANTER

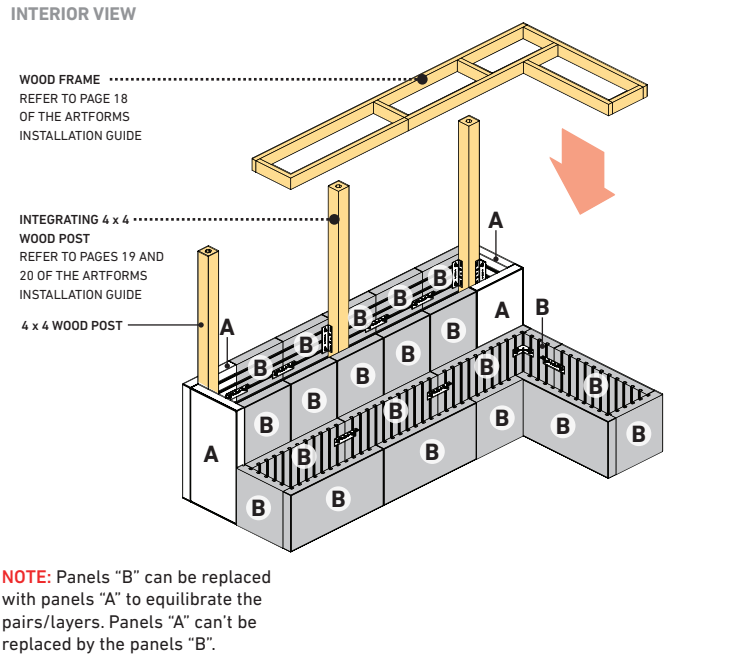

**REQUIRED PANELS**

CLOSED END  
18 x 36 PANEL **4x**

AOR B  
18 x 36 PANEL **20x**

CLOSED END  
6 x 36 PANEL **0x**

COR D  
6 x 36 PANEL **0x**

**IMPORTANT:** 18 x 36 panels are sold in pair/layer or in full pallet only. 6 x 36 panels are sold per unit or in layer or in full pallet.

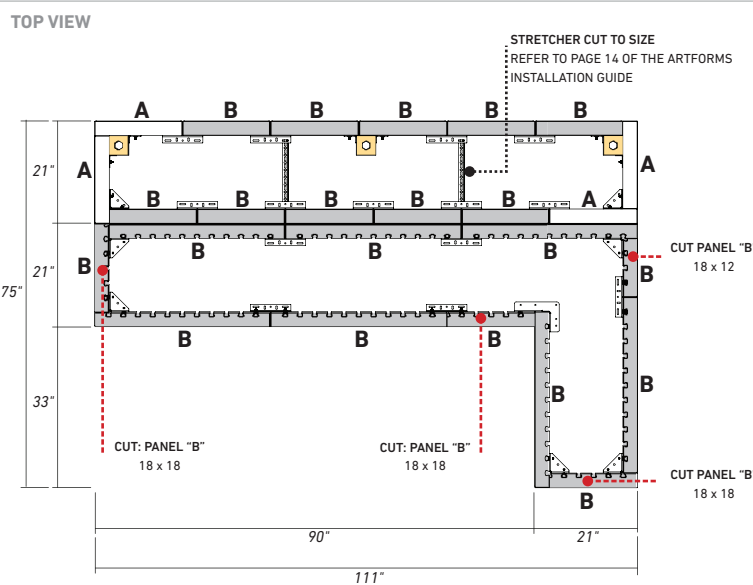
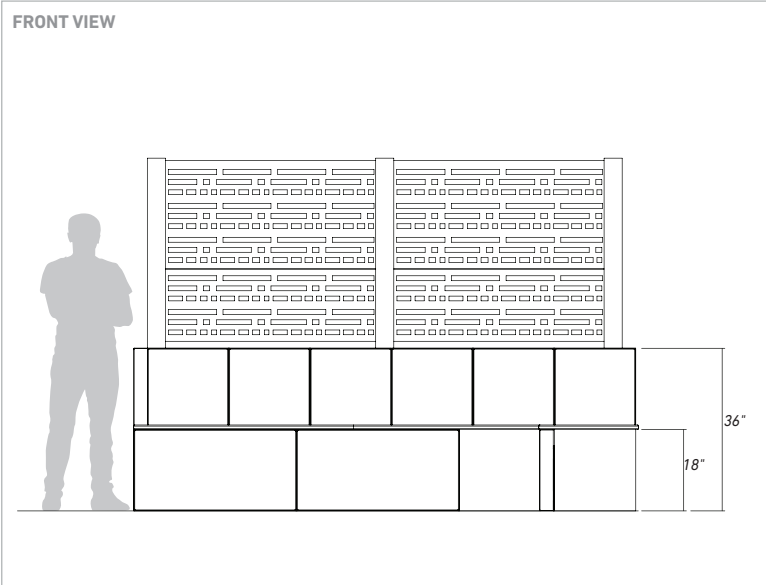

**REQUIRED HARDWARE**

ANCHOR SLIDE AND NUT **116x**

JOINING PLATE **40x**

OUTER CORNER **14x**

INNER CORNER **2x**

STRETCHER **1x**

**IMPORTANT:** Refer to page 23 of the ARTFORMS INSTALLATION GUIDE about the installation of geotextile in planter box. Contact experts/engineers to validate the base preparation, the drainage, the plants & roots growth/management.

**TOTAL WEIGHT (PANELS & HARDWARE) 3615 Lbs**



# 30. HIGH TOP GAS FIRE PIT

Gas Option



Propane Option





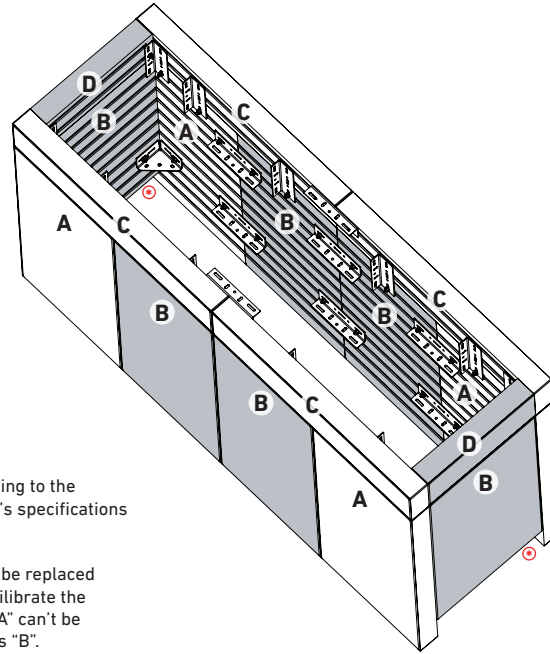

INTERIOR VIEW

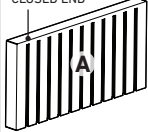

Ⓢ Cut panel(s) according to the burner manufacturer's specifications for ventilation.

**NOTE:** Panels "B" can be replaced with panels "A" to equilibrate the pairs/layers. Panels "A" can't be replaced by the panels "B".

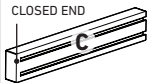
REQUIRED PANELS

-  18 x 36 PANEL **4x**
-  18 x 36 PANEL **6x**
-  6 x 36 PANEL **4x**
-  6 x 36 PANEL **2x**

**IMPORTANT:** 18 x 36 panels are sold in pair/layer or in full pallet only. 6 x 36 panels are sold per unit or in layer or in full pallet.

FRONT VIEW

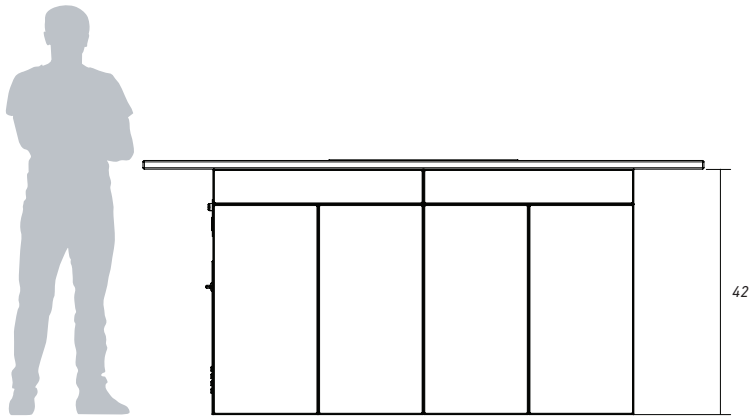

TOP VIEW

18 x 36 PANELS

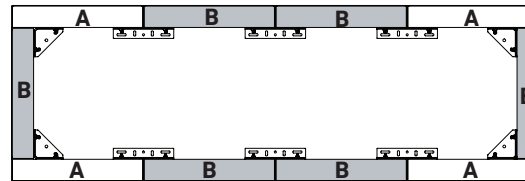



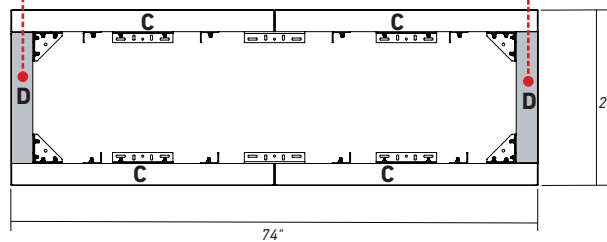

6 x 36 PANELS

CUT PANELS "D"  
6 x 18

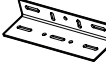

REQUIRED HARDWARE

-  ANCHOR SLIDE AND NUT **60x**
-  JOINING PLATE **26x**
-  OUTER CORNER **4x**
-  INNER CORNER **0x**
-  STRETCHER **0x**

**IMPORTANT:** It is recommended to follow the FIREKIT manufacturer's specifications for ventilation and clearances. Belgard is not responsible for the conformity of connections, clearances and ventilation. Burner pan, countertop and accessories are not included.

**TOTAL WEIGHT (PANELS & HARDWARE) 1707 Lbs**

# 31. CORNER BENCH & FIRE PIT



**INTERIOR VIEW**  
18 x 36 PANELS

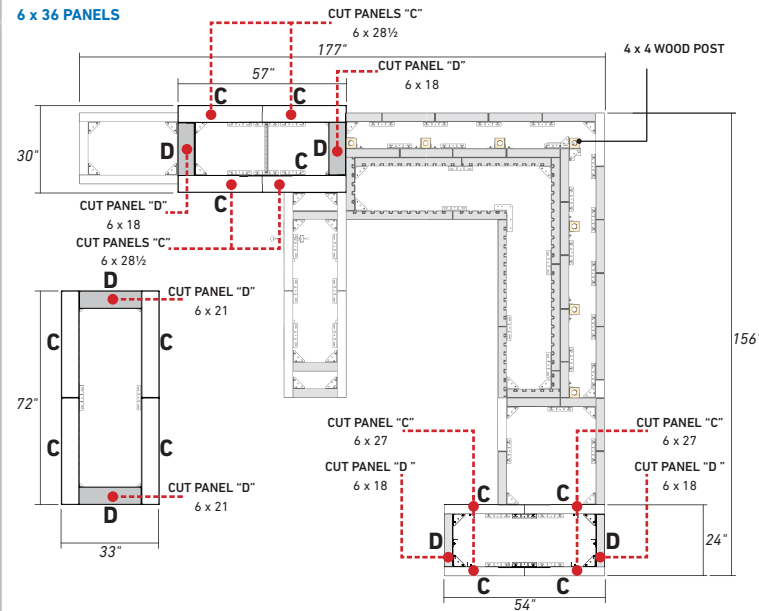
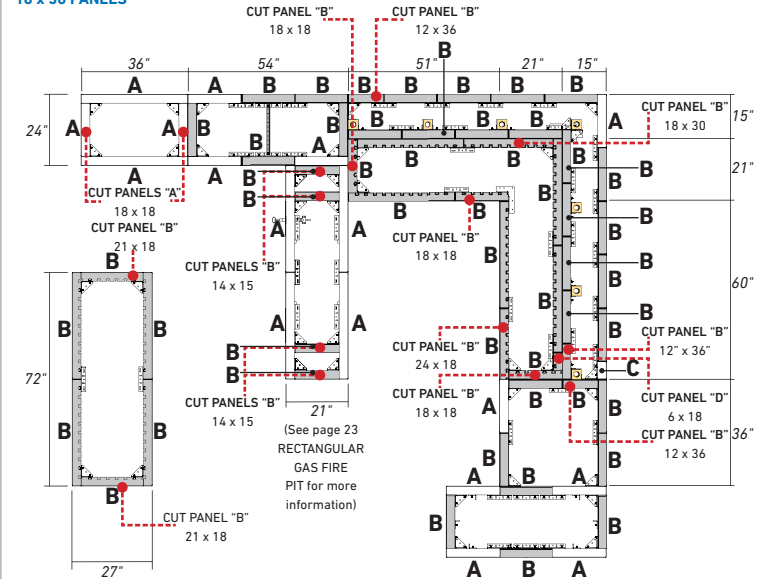

**FRONT VIEW**

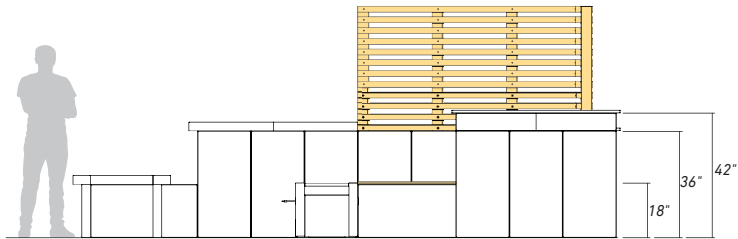
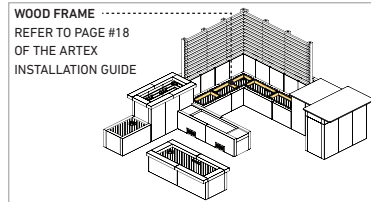

**NOTE:** Panels "B" can be replaced with panels "A" to equilibrate the pairs/layers. Panels "A" can't be replaced by the panels "B".

**IMPORTANT:** It is recommended to follow the FIREKIT manufacturer's specifications for ventilation and clearances. Belgard is not responsible for the conformity of connections, clearances and ventilation. Burner pan, countertop and accessories are not included.

## REQUIRED PANELS

- CLOSED END  
18 x 36 PANEL **18x**
- 18 x 36 PANEL **49x**
- CLOSED END  
6 x 36 PANEL **13x**
- 6 x 36 PANEL **5x**

**IMPORTANT:** 18 x 36 panels are sold in pair/layer or in full pallet only. 6 x 36 panels are sold per unit or in layer or in full pallet.

## REQUIRED HARDWARE

- ANCHOR SLIDE AND NUT **372x**
- JOINING PLATE **112x**
- OUTER CORNER **80x**
- INNER CORNER **4x**
- STRETCHER **1x**

**TOTAL WEIGHT**  
(PANELS & HARDWARE) **9798 Lbs**

# 31. CORNER BENCH & FIRE PIT

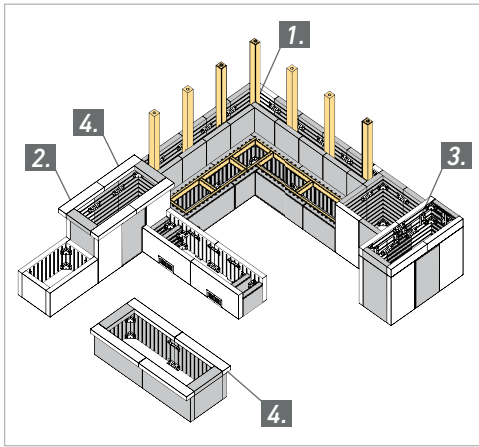

**1.** Drill the concrete panel to install the Concrete Screw Anchors, and the wood post to install the Stainless Steel Screw.

**NOTE:**  
**X:** Stainless Steel Wood Screw Flat Head #10 x 2 1/2"  
**Y:** Concrete screw anchor (Tapcon®) 1/4 x 1 3/4 or 3/8 x 1 3/4

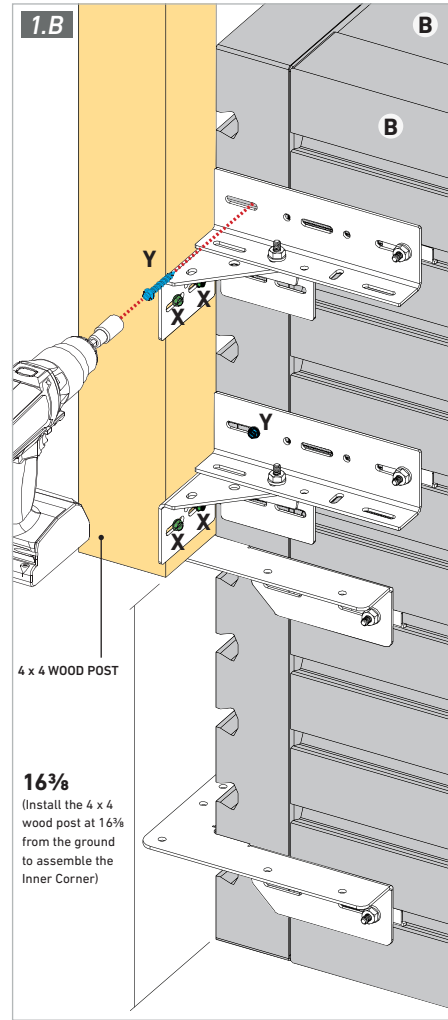
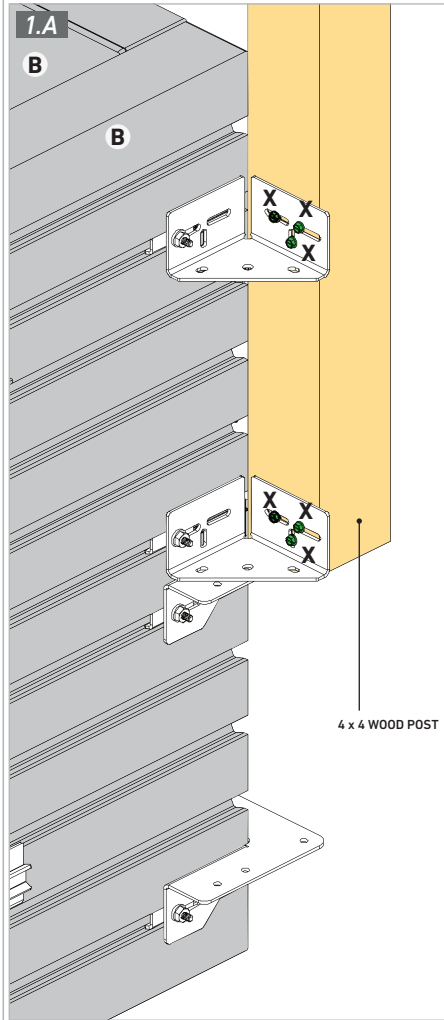
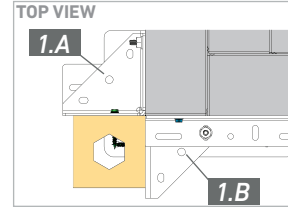

4 x 4 WOOD POST

**16 3/8**  
 (Install the 4 x 4 wood post at 16 3/8 from the ground to assemble the Inner Corner)

## VERTICAL & HORIZONTAL PLANTER BOX

**2.** OPTIONAL: LED strip can be inserted in the dovetail. Refer to page 16 of the ARTEX INSTALLATION GUIDE.

**4.** The panels 6 x 36 are glued using CONSTRUCTION GLUE or STRUCTURE BOND.

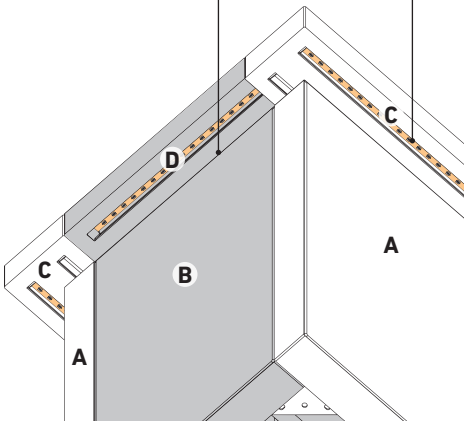

## 3. EXPLODED VIEW - BAR TABLE

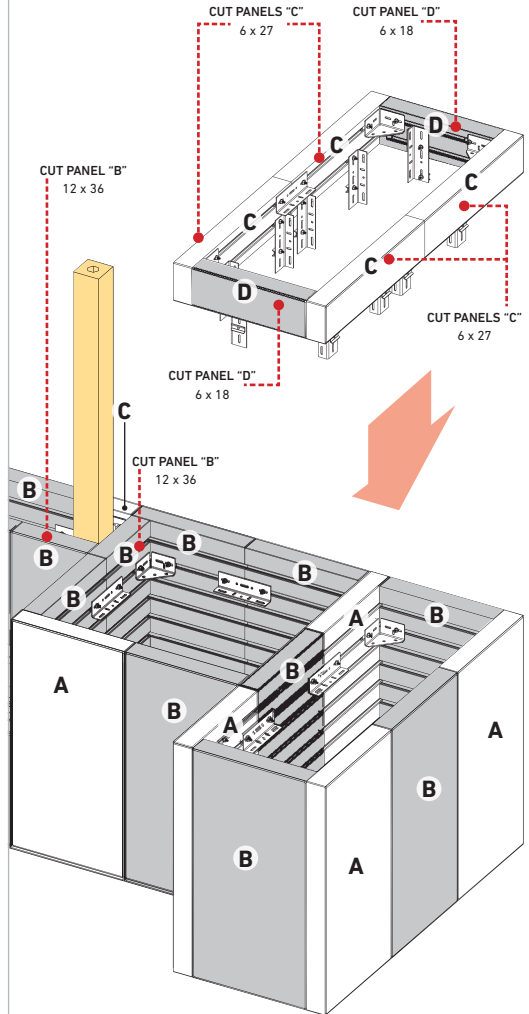

**IMPORTANT:** It is recommended to follow the manufacturer's specifications for LED stripes and wire connections. Belgard is not responsible for the conformity of the LED strip inserts.

